

Labor

Dental Lab

DFS

Dental Future Systems

D I A M O N

www.dfs-diamon.de

2017 / 2018

HOCHWERTIGE UND INNOVATIVE
DENTALPRODUKTE
SEIT MEHR ALS 30 JAHREN.

*DEVELOPING AND MANUFACTURING
INNOVATIVE DENTAL PRODUCTS
FOR OVER 30 YEARS.*

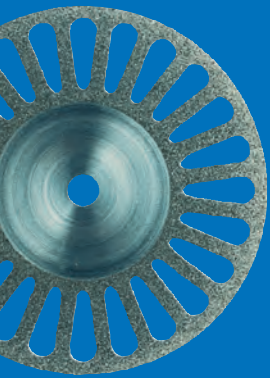



DFS DIAMON: Seit über 30 Jahren erfolgreich in Entwicklung, Produktion und Vertrieb zahnmedizinischer und zahn-technischer Erzeugnisse.

DFS DIAMON: excellence in product development, manufacturing and distribution of dental/medical products for over 30 years.



Inhaltsverzeichnis / Content

	Seite / page		Seite / page
EN ISO Norm / EN ISO code	5	Galvanische Diamantschleifer HST /	
Uni-Disk / Uni-disc	6	Electroplated HP diamonds	38-44
DIADUR Hartmetallfräser / DIADUR Carbide Cutters	8-25	Galvanische Diamantschleifer HST in verdichteter Diamantierung /	
Turbo	9	Electroplated HP diamonds in dense diamond coating	44
Tri-Bur, Quatt-Cutter, Mini-Tri, Tri-Cutter, Cross-Cutter	9	Lithium Disilikat Set / Tool set for lithium disilicate	45
Macro	9-10	Flexible Diamantscheiben / Flexible diamond discs	45-52
Quattro	11-12	Firmoflex	45
Strato	12	Spiroflex	45
Quattro-Twin	12	Plexoflex	46
Bibur	12	Sepaflex	46
Macronom	13	Polyflex	46
Ergonom	13	Tri-Flex	46
Micro	13-14	Circo-Flex	46
Golden-Micro	14-15	Techno I - IV	47
Golden-Quattro	15	Transoflex	47
Matro	15	Perfocut	48
Milli-Micron	16	Rapido-Cut	48
Nuevo	16	Sensoflex	48
Super-Tech	17	Cutflex	48
Titano	17-18	Laserflex	49
Star	18	Toto-Flex	49
Super-Star	18	Toro-Flex	50
Blue Star	19-20	Flexiflex	50
Okklu-Point	21	Cono-Disc	51
Fipol	21	Super-Flexiflex	51
Soft Liner	21	Double Action	52
DIADUR Hartmetallbohrer / DIADUR Carbide Burs	22-25	Top-Flex	52
SIDIA Sinterdiamanten / SIDIA Sintered Diamonds	27-31	Mini-Flex	52
FG Macro	27	Hydroflex	52
FG Micro	27	Trennscheiben / Separating Discs	53
HP Macro	27	Shark Discs	53
HP Micro	28	Power Cut	53
Superturbo	28	Golden Devil	53
Turbo	28	Gipstrennscheiben / Plaster discs	54-55
Macro	29	Plaster Disc	54
Micro	29-30	High-Tech	54
Milli-Micron	31	Plastro	54
Reinigungssteine / Cleaning Stones	31	Gipstrennscheiben / Plaster Cut Discs	55
SIDIA Sinterdiamantscheiben / SIDIA Sintered Diamond Discs	32	Spezial Instrumente / Special Instruments	56
Macro	32	Stahldrahtbürste / Wire Brush Wheel	56
Micro	32	Stahldrahtpinsel / Wire Brush	56
Galvanische Sinterscheibe / Electroplated Diamond Disc	32	Mandrelle / Mandrels	56
Zirkonbearbeitung / Zirconia instruments	33-36	Reduzierstücke / Reducers	56
Circool Lab XL	33	Quick Fix Mandrell / Quick Fix mandrel system	57-59
Circool Lab	33	Smart Fox Mandrell / Smart fox mandrel system	60-61
Circopol Lab	34	Upofix Universal Polierer / Upofix Universal polishers	62-64
SIDIA FG	34	Polierinstrumente / Polishing Instruments	64-66
FG Zirkondiamanten / FG Zirconia diamonds	34	Unifix	64
Zirkondiamanten HST / HP Zirconia Diamonds	34	Goat Fix	64
Sepaflex / Sidiaflex Gold	35	Supershiny	65
Circone	35	Hypofix-Gamma	65
Zirkonset / Zirconia Kit	36	Hypofix-Delta	65
Sonder Diamant Schleifer /		Diafix	66
Electroplated spiral diamond finishers	36-37	Polierbürsten / Polishing brush wheels	66-67
Löffelrandschleifer / Periphery Finisher	36	Hypofix-Polacryl	66
Alveolarschleifer / Alveolar Finisher	36	Hypofix-Alpha	67
Pinfix	36	Hypofix-Beta	67
Plasturbo	37		
Gusskanalschleifer / Sprue Finisher	37		
Turbo Diamant Schleifer / Turbo Diamond Grinders	37		

Inhaltsverzeichnis / Content

	Seite / page		Seite / page
Spezial Polierer / <i>Special Polishers</i>	68-72	Okkluflex	93-94
Duro-Pol	68	Wachshilfsteile / <i>Wax: modelling help</i>	95-96
Palapol	68	Wachsflexetten / <i>Wax patterns</i>	97-98
Sabelking	69	Wachsglättungspinsel / <i>Wax smoothing brush</i>	98
Uni-Pol	69	Li-Bond Pen	99
Multipol	69-70	Geschiebetchnik / <i>Plastic Attachments</i>	100-101
Silco-Pol	70	Gießtechnik / <i>Casting technology</i>	102-108
Top-Glaze	70-71	Thermofix	102-106
Polo	71	Einbettmassen / <i>Investments</i>	107-108
Polli	71	Expansionsliquid / <i>Expansion liquid</i>	108
Titanopol	72	Haftspray / <i>Adhesive spray</i>	109
Frästechnik / <i>Milling Technique</i>	72-80	Separierspray / <i>Separation spray</i>	109
Wachsfräser 0° / <i>Wax Cutter 0°</i>	72	NE-Legierungen / <i>Non precious alloys</i>	110-111
Fräser 0° / <i>Milling Burs 0°</i>	72-74	Biodur Soft	110
Millipol 0°	74	Niadur	110
Twisters	75	Diadur	111
Bohrfräser / <i>Centering Bur</i>	75	Flussmittel / <i>Flux material</i>	111
Stirnfräser / <i>Shoulder Cutting Burs</i>	75	Lot / <i>Solder</i>	112
Rillenfräser / <i>Groove Cutters</i>	75	Laserdraht / <i>Laser wire</i>	113
Wachsfräser 2° / <i>Wax Cutter 2°</i>	76	Keramikbearbeitung / <i>Ceramics tools</i>	114-119
Fräser 2° / <i>Milling Burs 2°</i>	76	Kera-Brush	114
Millipol 2°	76	Keramikpinsel / <i>Ceramic brushes</i>	114-116
Wachsfräser 4° / <i>Wax Cutter 4°</i>	76	Zangen / <i>Forceps</i>	117-118
Fräser 4° / <i>Milling Burs 4°</i>	76	Crowny	118
Millipol 4°	77	Teleskofix	118
Wachsfräser 6° / <i>Wax Cutter 6°</i>	77	Teleskogrip	118
Fräser 6° / <i>Milling Burs 6°</i>	77	Kera-Set Tray	118
Übertragungstern / <i>Transfer Jig</i>	77	Brenngutträger, Metallstifte / <i>Ceramic trays, pins</i>	118-119
Frästechnik in 3mm Schaft / <i>Milling technique in 3mm shank</i> ..	78	Diamantspray / <i>Diamond spray</i>	120
Implantan Titanfräser / <i>Implantan milling burs for titanium</i> ..	79	Polierpaste / <i>Polishing paste</i>	120
Gips / <i>Plaster</i>	80	Texturmarker / <i>Texture marker</i>	121
Gipsbearbeitung / <i>Plaster tools</i>	81-83	Orangenreiniger / <i>Orange cleaner</i>	121
Plastrim	81	Okklusionsspray / <i>Occlusion spray</i>	122
TopGlue Sekundenkleber / <i>TopGlue speed glue</i>	81	Telescan Spray / <i>Telescan spray</i>	123
Silikonspray / <i>Silicone spray</i>	81	Lötenschutzpaste / <i>Solder heat protection paste</i>	123
Plastodur	82	Crown Master	124
Isofix	82	Bearbeitungs-Sets / <i>Tool kits</i>	125-127
Durolan Stumpflack / <i>Durolan die spacer</i>	82-83	Index	128-129
Dubiergel / <i>Duplicating gel</i>	84		
Unterfütterung: Okklamat / <i>Relining: Okklamat</i>	85		
Galvanet Silberleitlack / <i>Galvanet conductive lacquer</i>	85		
Modellierinstrumente / <i>Modelling instruments</i>	86-88		
Tauchwachs / <i>Dipping wax</i>	89		
Silikon- und Wachsentspanner / <i>Debubblizer</i>	89		
Wachs / <i>Wax</i>	90-92		
DFS Wachs / <i>DFS wax</i>	90		
Wachsdraht / <i>Wax wire</i>	91		
Gußbirnen / <i>Casting pears</i>	92		

Die Standardisierung von rotierenden Werkzeugen gemäß EN ISO - Norm 6360

All our tools are manufactured according to EN ISO-Standard 6360

Von der Internationalen Standardisierungsorganisation (ISO) wurden eine Reihe von Konventionen hinsichtlich der Bezeichnung von rotierenden Werkzeugen in der Dentaltechnik eingeführt. Jedes Werkzeug wird mit einem international eindeutigen ISO-Nummerncode gekennzeichnet. Dieser Nummerncode besteht aus 15 Ziffern in 5-Gruppen und beinhaltet gleichzeitig die Beschreibung der Werkzeugeigenschaften.

In order to achieve conformity the International Standards Organization (ISO) has defined a standard description of dental rotary instruments. Each instrument is assigned a distinct ISO number code consisting of 15 digits in 5 subgroups which simultaneously contain the description of each instrument.

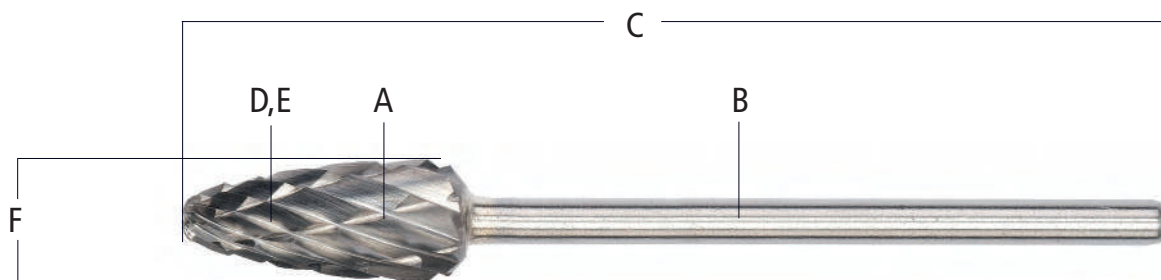

ISO-Nr.	500	104	274	190	060
	A	B, C	D	E	F

- A Werkstoff des Arbeitsteils
Material of the working part z.B. 500 für Hartmetall
e.g. 500 for carbides
- B,C Schaft und Gesamtlänge
Shank and total length z.B. 104 für Standard-Handstück
e.g. 104 for straight hand piece
- D Form und Ausführung
Cutting surface or grit size z.B. 274 für die Form des Arbeitsteils
e.g. 274 for the shape of the working part
- E Verzahnung
Design of the cut z.B. 190 für die Verzahnung
e.g. 190 for the cut design
- F Durchmesser
Diameter größter Durchmesser des Arbeitsteils in 0,1 mm
largest diameter of the working part in 0.1 mm

Die von uns angebotenen Werkzeuge folgen der ISO-Norm und können daher eindeutig über den ISO-Nummerncode identifiziert werden.

All DFS-DIAMON instruments are manufactured according to the ISO standard and can be clearly identified by the ISO code.

Uni-disc

Hält Spannzange
und Lager sauber!
*Keeps chuck and
bearings clean!*

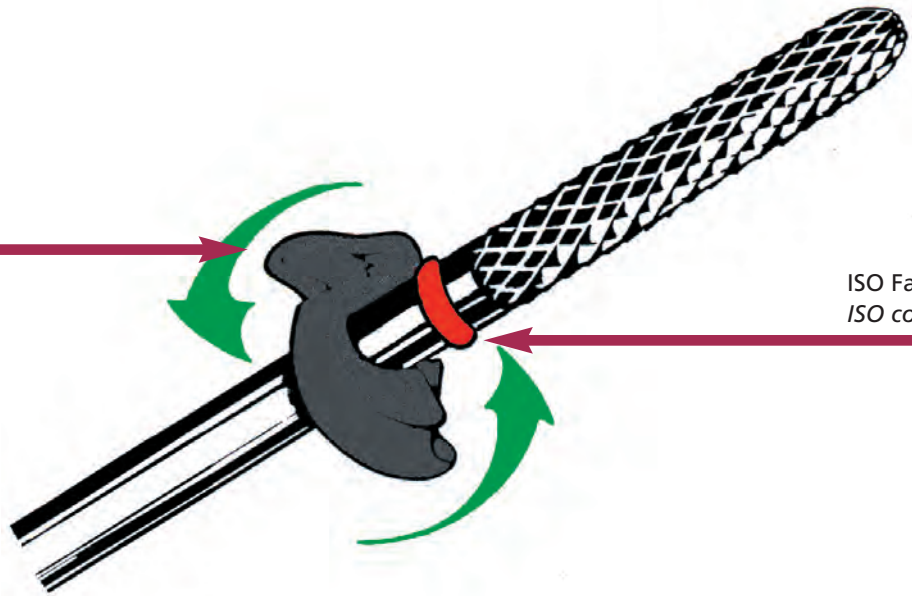

ISO Farbring
ISO colour ring



Die korrekte Position im Handstück!
Correct insertion of instrument!



Immer eine Schutzbrille tragen!
Always wear safety goggles!

Ihre Vorteile / *Your benefits*

Ausgezeichnete Qualität / *Cutting edge technology with exceptional quality*

- Made in Germany

- Modernste Fertigungstechnologien

Cutting-edge manufacturing technology

- Farbcodiert für optimale Effizienz

Um beste und schnellste Ergebnisse zu erzielen, sollten die Instrumente in der Reihenfolge der Farbcodierung eingesetzt werden. Von dunkel nach hell oder 1 bis 6. HM-Fräser und Diamantwerkzeuge sind untereinander auswechselbar.

Color-coded for optimum efficiency

For best results use instruments in sequence following the colour-coding from dark to light (1-6).

Carbides and diamonds are interchangeable as long as you follow the color-coding.

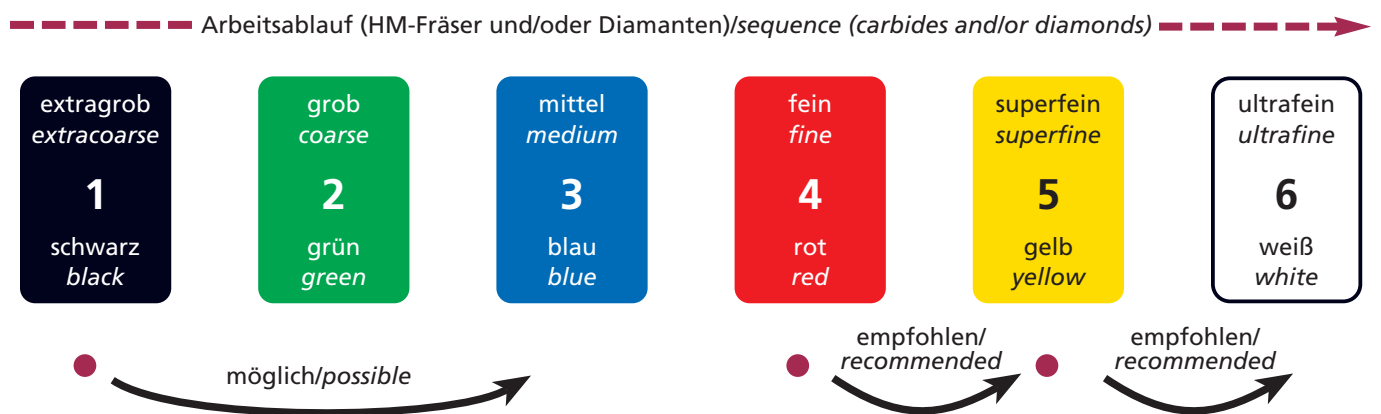

- Hinweis: Wir empfehlen, nicht mehr als eine Farbe zu überspringen!
1 auf 3 ist möglich, 1 auf 5 ist nicht empfehlenswert, da zu hoher Material- oder Zeitaufwand!

Note: We recommend not to skip more than one color.

Moving from black to blue (1-3) is possible; moving from black directly to yellow (1-5) is inefficient and/or a waste of time.

- Auf dem Werkzeugschaft befinden sich der Verzahnung/Körnung entsprechende Farbringe.

Each instrument is color-coded according to cut/grit size.

DIADUR die neue Generation der Hartmetallfräser

DIADUR the new generation of carbide cutters

Der neue mikrostrukturierte Hartmetallfräser ist in zukunftsweisender Produktionstechnologie gefertigt.
The new micro - structure carbide cutter is manufactured with today's most advanced technology.

Ihre Vorteile

Benefits and advantages

- Verlängerte Lebensdauer auch bei intensivem Einsatz
Extended lifetime even in case of intensive use
- Außergewöhnlich hohe Rundlaufgenauigkeit < 0,015 mm, dadurch leiser und vibrationsarmer Lauf und Schonung der Antriebslager Ihrer Handstücke
Precise instrument balance (less than 0.015 mm), therefore smoother running of your handpiece, reduces vibration and protects chuck and bearings
- Optimale Oberflächenqualität Ihrer Werkstücke
Optimal surface of workpieces
- Verbesserter Abtrag durch innovative Schneidengeometrie
Improved cutting efficiency due to innovative cutting geometries
- Einfaches Arbeiten auch nach längerem Gebrauch
Easy to work even after extended use

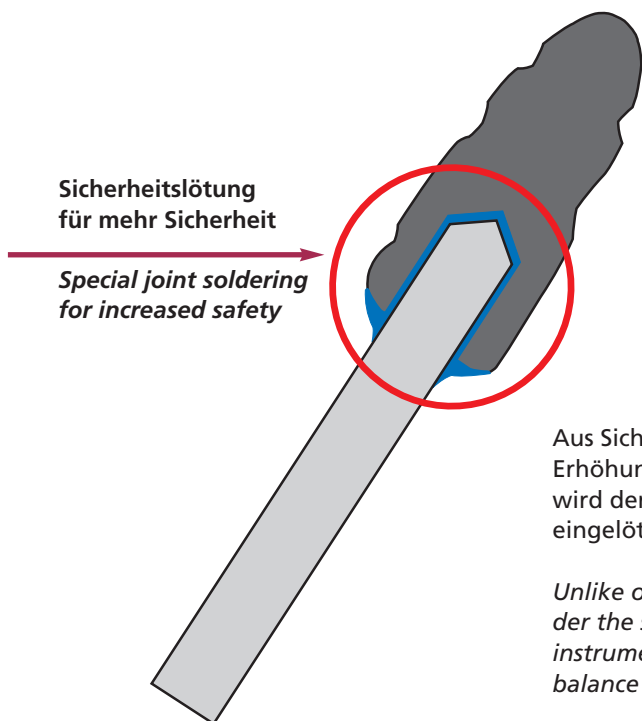

Aus Sicherheitsgründen und zur Erhöhung der Rundlaufgenauigkeit wird der Schaft in den HM-Kopf eingelötet.

Unlike other manufacturers, we solder the shanks into the head of our instruments resulting in improved balance and safety.

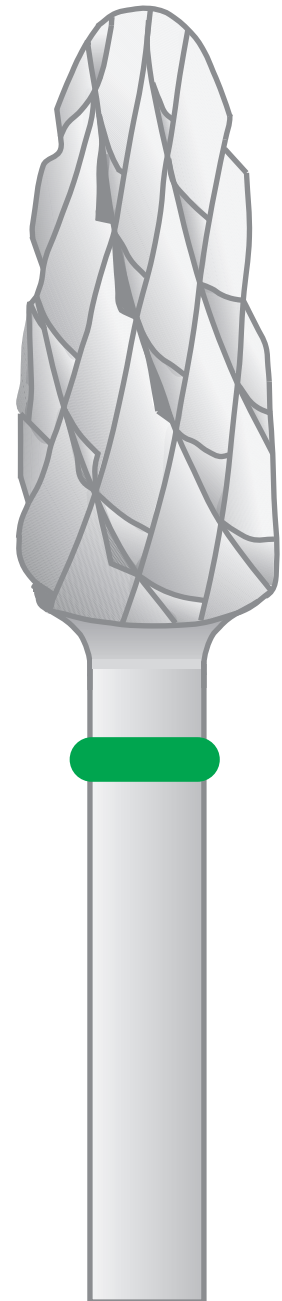

DIADUR Hartmetallfräser / DIADUR carbide cutters



Verzahnung / Crosscut
 ISO 223
 ISO-Nr.
 500 104 ...
 Figur-Nr. / Shape #
 ø 1/10 mm
 VE / packaging unit



TURBO
 15' - 25000 Upm/rpm

144	200	200	201	275	275
060	040	060	070	060	060
1	1	1	1	1	1

509901 509201 557701 509101 509001 559001

Order-Nr.



Verzahnung / cut
 ISO 377
 ISO-Nr.
 500 104 ...
 Figur-Nr. / Shape #
 ø 1/10 mm
 VE / packaging unit

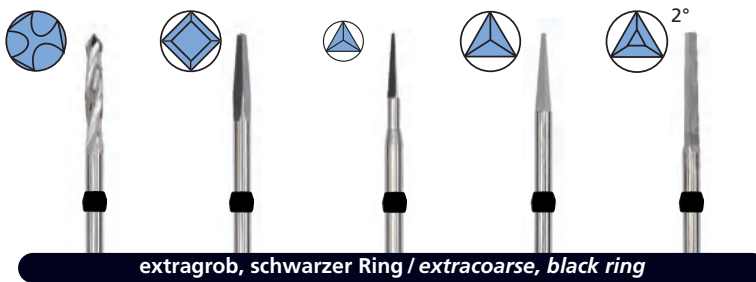

extragrob, schwarzer Ring / extracoarse, black ring

TRI-BUR	QUATT-CUTTER	MINI-TRI	TRI-CUTTER	CROSS-CUTTER
5' - 10000 Upm/rpm				
448	467	468	468	471
023	023	016	023	023
1	1	1	1	1

80033 80031 80059 80049 80055

Order-Nr.



Verzahnung / Crosscut
 ISO 220
 ISO-Nr.
 500 104 ...
 Figur-Nr. / Shape #
 ø 1/10 mm
 VE / packaging unit



grob, grüner Ring / coarse, green ring

MACRO
 15' - 30000 Upm/rpm

001	001	001	113	113	122	141	144	145
023	040	060	023	060	023	023	060	023
1	1	1	1	1	1	1	1	1

406702 405001 408301 408502 407801 406502 405102 407901 406402

Order-Nr.

Anwendung/Application



- Gips
Plaster
- Schellack
Thermoplastics
- Löffelmaterial
Tray material
- Epoxy-Modellstumpfmateriale
Epoxy models
- Prothesen-Kunststoffe
Heat and self curing acrylics



- Zum schmierfreien Schneiden von sämtlichen Kunststoffen.
For cutting of thermoplastic and tray material.

CROSSCUTTER
 • Kunststoff und Gips
Acrylics and plaster

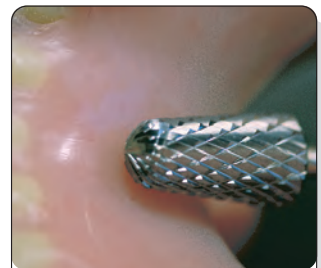

- Co-Cr Legierungen
Cobalt chrome alloys
- Gips
Plaster
- Prothesen-Kunststoffe
Heat, self and light curing acrylics

DIADUR Hartmetallfräser / DIADUR carbide cutters



Verzahnung / Crosscut
ISO 220
ISO-Nr.
500 104 ...
Figur-Nr. / Shape #
ø 1/10 mm
VE / packaging unit



grob, grüner Ring / coarse, green ring

	MACRO							
	15' - 30000 Upm/rpm							
Figur-Nr. / Shape #	186	187	198	198	199	200	200	200
ø 1/10 mm	060	023	018	023	023	023	040	045
VE / packaging unit	1	1	1	1	1	1	1	1
Order-Nr.	407501	406302	404902	404802	406202	406102	406801	403201



Verzahnung / Crosscut
ISO 220
ISO-Nr.
500 104 ...
Figur-Nr. / Shape #
ø 1/10 mm
VE / packaging unit



grob, grüner Ring / coarse, green ring

	MACRO							
	15' - 30000 Upm/rpm							
Figur-Nr. / Shape #	200	201	201	201	237	237	237	251
ø 1/10 mm	060	050	060	070	023	060	070	060
VE / packaging unit	1	1	1	1	1	1	1	1
Order-Nr.	407701	406901	407201	407401	404602	408101	407101	408001



Verzahnung / Crosscut
ISO 220
ISO-Nr.
500 104 ...
Figur-Nr. / Shape #
ø 1/10 mm
VE / packaging unit



grob, grüner Ring / coarse, green ring

	MACRO					
	15' - 30000 Upm/rpm					
Figur-Nr. / Shape #	274	275	277	289	292	292
ø 1/10 mm	040	060	060	023	023	060
VE / packaging unit	1	1	1	1	1	1
Order-Nr.	403301	407001	407301	405002	406602	407601

Anwendung / Application



- Co-Cr Legierungen
Cobalt chrome alloys
- Gips
Plaster
- Prothesen-Kunststoffe
Heat, self and light curing acrylics

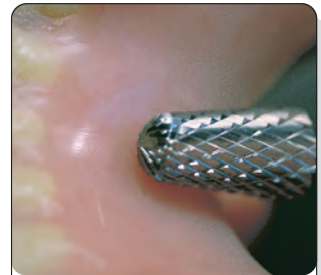

- Co-Cr Legierungen
Cobalt chrome alloys
- Gips
Plaster
- Prothesen-Kunststoffe
Heat, self and light curing acrylics



- Co-Cr Legierungen
Cobalt chrome alloys
- Gips
Plaster
- Prothesen-Kunststoffe
Heat, self and light curing acrylics

DIADUR Hartmetallfräser / DIADUR carbide cutters



Verzahnung / Crosscut
ISO 190
ISO-Nr.
500 104 ...
Figur-Nr. / Shape #
ø 1/10 mm
VE / packaging unit



mittel, blauer Ring / medium, blue ring

QUATTRO
15' - 30000 Upm / rpm

001	001	001	001	114	137	142	143	185
023	027	040	050	023	060	023	023	023
1	1	1	1	1	1	1	1	1

Order-Nr.
606702 605602 605001 605201 608502 607901 602402 606402 602102



Verzahnung / Crosscut
ISO 190
ISO-Nr.
500 104 ...
Figur-Nr. / Shape #
ø 1/10 mm
VE / packaging unit

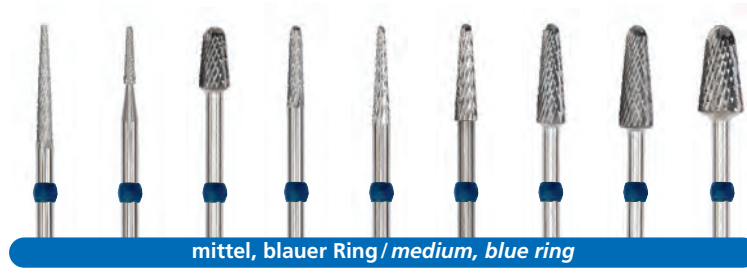

mittel, blauer Ring / medium, blue ring

QUATTRO
15' - 30000 Upm/rpm

187	198	198	199	200	200	200	200	200
023	016	040	023	023	031	040	045	060
1	1	1	1	1	1	1	1	1

Order-Nr.
602302 605902 606001 602202 606102 605502 606801 603201 602701



Verzahnung / Crosscut
ISO 190
ISO-Nr.
500 104 ...
Figur-Nr. / Shape #
ø 1/10 mm
VE / packaging unit



mittel, blauer Ring / medium, blue ring

QUATTRO
15' - 30000 Upm/rpm

201	201	201	225	237	237	250	260
050	060	060	023	029	060	023	060
1	1	1	1	1	1	1	1

Order-Nr.
602901 607201 607501 604702 605302 608101 602602 603401

Anwendung / Application

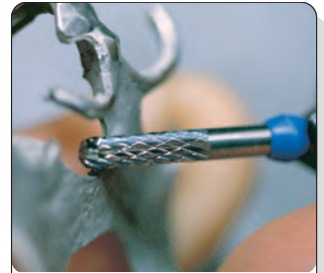

- Co-Cr Legierungen
Cobalt chrome alloys
- NE-Legierungen
Non-precious alloys
- Edelmetall-Legierungen
Precious alloys
- Reduzierte-Edelmetall-Legierungen
Semi-precious alloys



- Co-Cr Legierungen
Cobalt chrome alloys
- NE-Legierungen
Non-precious alloys
- Edelmetall-Legierungen
Precious alloys
- Reduzierte-Edelmetall-Legierungen
Semi-precious alloys

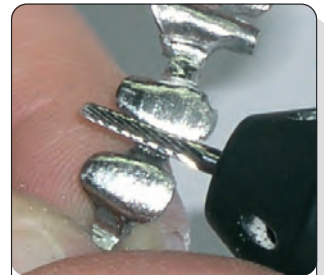

- Co-Cr Legierungen
Cobalt chrome alloys
- NE-Legierungen
Non-precious alloys
- Edelmetall-Legierungen
Precious alloys
- Reduzierte-Edelmetall-Legierungen
Semi-precious alloys

DIADUR Hartmetallfräser / DIADUR carbide cutters



Verzahnung / Crosscut
ISO 190
ISO-Nr.
500 104 ...
 Figur-Nr. / Shape #
 ø 1/10 mm
 VE / packaging unit

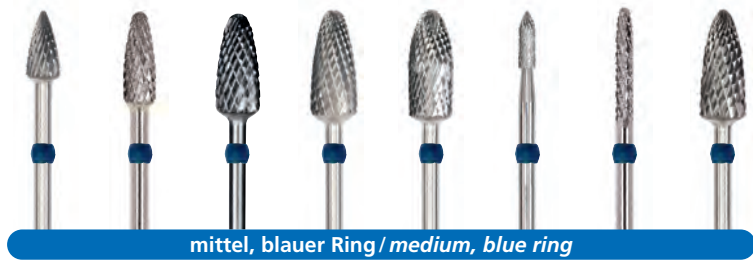

mittel, blauer Ring / medium, blue ring

QUATTRO							
15' - 30000 Upm/rpm							
273	274	274	275	277	289	292	292
045	040	060	060	060	023	023	060
1	1	1	1	1	1	1	1
602301	603301	603501	602001	607301	605002	606602	607601
●	●	●	●	●	●	●	●

Anwendung / Application

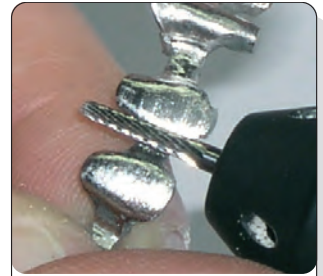

- Co-Cr Legierungen
Cobalt chrome alloys
- NE-Legierungen
Non-precious alloys
- Edelmetall-Legierungen
Precious alloys
- Reduzierte-Edelmetall-Legierungen
Semi-precious alloys



Verzahnung / Crosscut
ISO 022
ISO-Nr.
500 104 ...
 Figur-Nr. / Shape #
 ø 1/10 mm
 VE / packaging unit



mittel, blauer Ring / medium, blue ring

STRATO				
15' - 25000 Upm/rpm				
200	200	237	274	275
023	040	040	040	060
1	1	1	1	1
416102	616801	415401	413301	417001
●	●	●	●	●

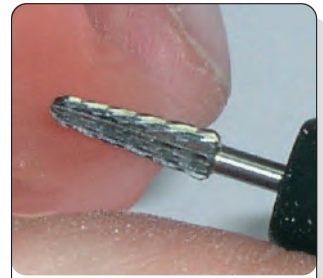

- Prothesen-Kunststoff
Heat, self and light curing acrylics
- Weichbleibende Kunststoffe
Soft lining material
- Valplast u.ä.
Valplast and similar

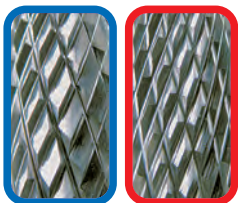

Verzahnung / Crosscut
ISO 190 / 140
ISO-Nr.
500 104 ...
 Figur-Nr. / Shape #
 ø 1/10 mm
 VE / packaging unit

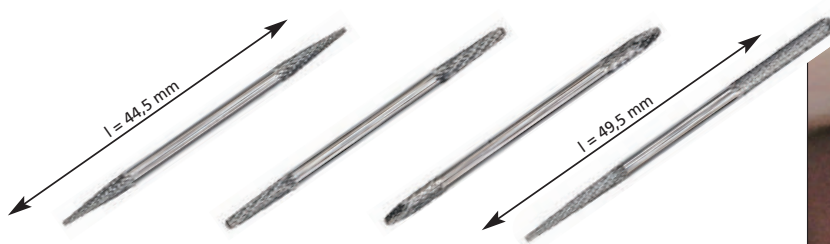

mittel / medium

fein / fine

QUATTRO -TWIN			BIBUR	
15' - 30000 Upm/rpm				
185	199	290	187/ 144	
023	023	023	023	
1	1	1	1	
602103	602203	602603	304103	
●	●	●	●	



- Co-Cr Legierungen
Cobalt chrome alloys
- NE-Legierungen
Non-precious alloys
- Edelmetall-Legierungen
Precious alloys
- Reduzierte-Edelmetall-Legierungen
Semi-precious alloys
- BIBUR: Komposite
BIBUR: Composites
- ohne Uni-Disk
no uni-disc

DIADUR Hartmetallfräser / DIADUR carbide cutters



Verzahnung / Crosscut
ISO 215
ISO-Nr.
500 104 ...
Figur-Nr. / Shape #
ø 1/10 mm
VE / packaging unit



grob, grüner Ring / coarse, green ring

MACRONOM

15' - 30000 Upm/rpm

194	194	239	257	275
045	060	060	060	060
1	1	1	1	1

424301

422701

425401

424401

422001

Order-Nr.

Anwendung/Application



- Gips
Plaster
- Kunststoffe
Acrylics



Verzahnung / cut
ISO 133
ISO-Nr.
500 104 ...
Figur-Nr. / Shape #
ø 1/10 mm
VE / packaging unit



fein, roter Ring / fine, red ring

ERGONOM

15' - 30000 Upm/rpm

145	187	195	199	200	275	292
023	023	014	023	040	060	023
1	1	1	1	1	1	1

100402

100302

105702

100202

100801

101001

100602

Order-Nr.

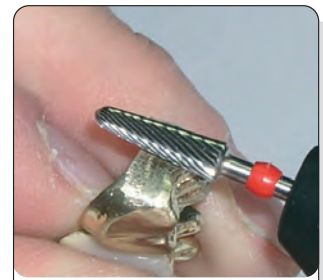

- Edelmetall-Legierungen
Precious alloys



Verzahnung / Crosscut
ISO 140
ISO-Nr.
500 104 ...
Figur-Nr. / Shape #
ø 1/10 mm
VE / packaging unit



fein, roter Ring / fine, red ring

MICRO

15' - 30000 Upm/rpm

113	123	141	144	145	187	195	198	198	198	198
060	023	023	060	023	023	014	016	018	023	040
1	1	1	1	1	1	1	1	1	1	1

303801

302502

305102

303901

302402

302302

305702

305902

304902

304802

306001

Order-Nr.



- Edelmetall-Legierungen
Precious alloys
- Reduzierte-Edelmetall-Legierungen
Semi-precious alloys
- Co-Cr Legierungen
Cobalt chrome alloys
- NE-Legierungen
Non-precious alloys
- Komposite
Composites

DIADUR Hartmetallfräser / DIADUR carbide cutters



Verzahnung / Crosscut
ISO 140
ISO-Nr.
500 104 ...
Figur-Nr. / Shape #
ø 1/10 mm
VE / packaging unit



fein, roter Ring / fine, red ring

MICRO									
15' - 30000 Upm/rpm									
199	200	200	200	200	200	201	201	201	225
023	023	031	040	045	060	050	060	060	023
1	1	1	1	1	1	1	1	1	1

Order-Nr.
302202 ● 306102 ● 305502 ● 302801 ● 303201 ● 303101 ● 302901 ● 303501 ● 307201 ● 304702 ●

Anwendung/Application



- Edelmetall-Legierungen
Precious alloys
- Reduzierte-Edelmetall-Legierungen
Semi-precious alloys
- Co-Cr Legierungen
Cobalt chrome alloys
- NE-Legierungen
Non-precious alloys
- Komposite
Composites



Verzahnung / Crosscut
ISO 140
ISO-Nr.
500 104 ...
Figur-Nr. / Shape #
ø 1/10 mm
VE / packaging unit



fein, roter Ring / fine, red ring

MICRO										
15' - 30000 Upm/rpm										
237	237	251	257	273	274	275	277	289	292	292
023	060	060	023	045	040	060	060	023	023	060
1	1	1	1	1	1	1	1	1	1	1

Order-Nr.
304602 ● 308101 ● 304001 ● 304502 ● 302301 ● 303301 ● 303001 ● 307301 ● 305002 ● 302602 ● 303601 ●



- Edelmetall-Legierungen
Precious alloys
- Reduzierte-Edelmetall-Legierungen
Semi-precious alloys
- Co-Cr Legierungen
Cobalt chrome alloys
- NE-Legierungen
Non-precious alloys
- Komposite
Composites



Verzahnung / Crosscut
ISO 140
ISO-Nr.
506 104 ...
Figur-Nr. / Shape #
ø 1/10 mm
VE / packaging unit



fein, roter Ring / fine, red ring

GOLDEN-MICRO								
15' - 30000 Upm/rpm								
113	141	145	186	198	198	199	200	201
060	023	023	023	018	023	023	040	050
1	1	1	1	1	1	1	1	1

Order-Nr.
303801T ● 305102T ● 302402T ● 302302T ● 304902T ● 304802T ● 302202T ● 302801T ● 302901T ●

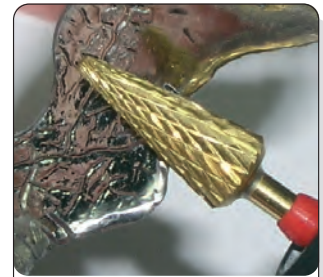

- Co-Cr Legierungen
Cobalt chrome alloys
- NE-Legierungen
Non precious alloys
- Reduzierte-Edelmetall-Legierungen
Semi-precious alloys
- Edelmetall-Legierungen
Precious alloys
- Komposite
Composites
- Ungesintertes Zirkon
Green-state zirconia

TIN-beschichtet
TIN coated

DIADUR Hartmetallfräser / DIADUR carbide cutters



Verzahnung / Crosscut
 ISO 140
 ISO-Nr.
 506 104 ...
 Figur-Nr. / Shape #
 ø 1/10 mm
 VE / packaging unit



fein, roter Ring / fine, red ring

GOLDEN-MICRO
 15' - 30000 Upm/rpm

201	225	237	257	275	289	292	292
060	023	023	023	060	023	023	060
1	1	1	1	1	1	1	1
303501T	304702T	304602T	304502T	303001T	305002T	302602T	303601T

Order-Nr.

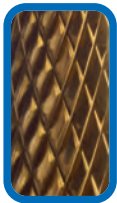

Verzahnung / Crosscut
 ISO 190
 ISO-Nr.
 506 104 ...
 Figur-Nr. / Shape #
 ø 1/10 mm
 VE / packaging unit



mittel, blauer Ring / medium, blue ring

GOLDEN-QUATTRO
 15' - 30000 Upm/rpm

107	200	201	237	274	275	289	292
023	040	050	029	040	060	023	023
1	1	1	1	1	1	1	1
602302T	606801T	602901T	605302T	603301T	602001T	605002T	606602T

Order-Nr.



Verzahnung / Crosscut
 ISO 015
 ISO-Nr.
 500 104 ...
 Figur-Nr. / Shape #
 ø 1/10 mm
 VE / packaging unit



fein, roter Ring / fine, red ring

MATRO
 15' - 30000 Upm/rpm

141	144	198	198	200	274	275	289
023	060	016	023	040	040	060	023
1	1	1	1	1	1	1	1
315102	313901	314902	314802	312801	313301	313001	315002

Order-Nr.

Anwendung / Application



- Co-Cr Legierungen
Cobalt chrome alloys
- NE-Legierungen
Non-precious alloys
- Reduzierte-Edelmetall-Legierungen
Semi-precious alloys
- Edelmetall-Legierungen
Precious alloys
- Komposite
Composites
- Ungesintertes Zirkon
Green-state zirconia

TIN-beschichtet
 TIN coated

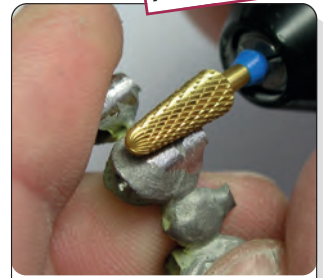

- Co-Cr Legierungen
Cobalt chrome alloys
- NE-Legierungen
Non-precious alloys
- Edelmetall-Legierungen
Precious alloys
- Reduzierte-Edelmetall-Legierungen
Semi-precious alloys
- Komposite
Composites

TIN-beschichtet
 TIN coated

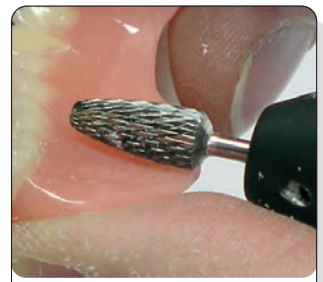

- Prothesen-Kunststoff
Heat, self and light curing acrylics
- Weichbleibende Kunststoffe
Soft lining material
- Valplast u.ä.
Valplast and similar

DIADUR Hartmetallfräser / DIADUR carbide cutters



Verzahnung / Crosscut
 ISO 110
 ISO-Nr.
 500 104 ...
 Figur-Nr. / Shape #
 ø 1/10 mm
 VE / packaging unit



MILLI-MICRON							
15' - 30000 Upm/rpm							
001	141	145	186	195	198	198	199
050	023	023	023	014	016	023	023
1	1	1	1	1	1	1	1
205201	205102	201402	201302	205702	204902	204802	201202

Order-Nr.

Anwendung/Application



- NE-Legierungen
Non-precious alloys
- Reduzierte-Edelmetall-Legierungen
Semi-precious alloys
- Edelmetall-Legierungen
Precious alloys
- Komposite
Composites



Verzahnung / Crosscut
 ISO 110
 ISO-Nr.
 500 104 ...
 Figur-Nr. / Shape #
 ø 1/10 mm
 VE / packaging unit



MILLI-MICRON						
15' - 30000 Upm/rpm						
200	200	200	237	275	289	292
023	040	045	023	060	023	023
1	1	1	1	1	1	1
206102	201801	203201	204602	203001	205002	201602

Order-Nr.

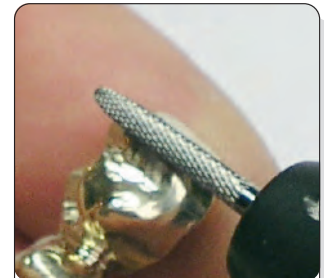

- NE-Legierungen
Non-precious alloys
- Reduzierte-Edelmetall-Legierungen
Semi-precious alloys
- Edelmetall-Legierungen
Precious alloys
- Komposite
Composites



Verzahnung / Crosscut
 ISO 134
 ISO-Nr.
 500 104 ...
 Figur-Nr. / Shape #
 ø 1/10 mm
 VE / packaging unit



NUEVO									
15' - 30000 Upm/rpm									
141	198	198	200	201	201	237	274	277	289
023	023	040	040	023	070	023	040	060	023
1	1	1	1	1	1	1	1	1	1
745102F	744802F	746001F	740801F	746102F	747401F	744602F	743301F	747301F	745002F

Order-Nr.



- Kunststoff (inkl. Valplast)
Acrylics (incl. Valplast)
- NE-Legierungen
Non-precious alloys
- Weichbleibende Kunststoffe
Soft lining materials

DIADUR Hartmetallfräser / DIADUR carbide cutters



Verzahnung / Crosscut
 ISO 145
 ISO-Nr.
 500 104 ...
 Figur-Nr. / Shape #
 ø 1/10 mm
 VE / packaging unit

fein, roter Ring / fine, red ring

SUPER-TECH									
15' - 30000 Upm/rpm									
141	145	187	198	200	237	274	275	289	292
023	023	023	018	040	023	040	060	023	023
1	1	1	1	1	1	1	1	1	1
905102	902402	902302	904902	902801	904602	903301	903001	905002	902602

Order-Nr.

Anwendung/Application

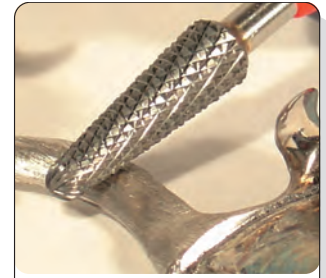

- Titan
Titanium
- Co-Cr Legierungen
Cobalt chrome alloys
- NE-Legierungen
Non-precious alloys

**3-fach verzahnt
3-way sectional cut**



Verzahnung / Crosscut
 ISO 154
 ISO-Nr.
 500 104 ...
 Figur-Nr. / Shape #
 ø 1/10 mm
 VE / packaging unit

extragrob, schwarzer Ring / extracoarse, black ring

TITANO					
15' - 30000 Upm/rpm					
141	145	198	200	289	292
023	023	023	040	023	023
1	1	1	1	1	1
735102F	736402F	734802F	730801F	735002F	736602F

Order-Nr.

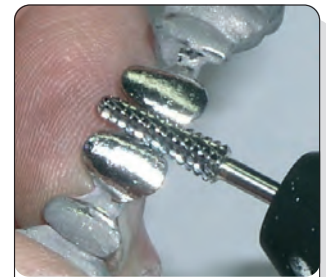

- Titan
Titanium

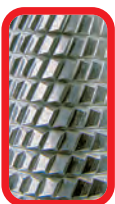

Verzahnung / Crosscut
 ISO 137
 ISO-Nr.
 500 104 ...
 Figur-Nr. / Shape #
 ø 1/10 mm
 VE / packaging unit

fein, roter Ring / fine, red ring

TITANO										
15' - 30000 Upm/rpm										
141	145	187	196	200	237	275	277	289	292	296
023	023	023	010	040	023	060	014	023	023	010
1	1	1	1	1	1	1	1	1	1	1
705102F	702402F	702302F	101102F	700801F	704602F	708001F	118080F	705002F	702602F	118050F

Order-Nr.



- Titan
Titanium
- NE-Legierungen
Non-precious alloys
- Komposite
Composites
- Lichthärtendes Löffelmaterial
Light curing tray material

DIADUR Hartmetallfräser / DIADUR carbide cutters



Verzahnung / Crosscut
ISO 112
ISO-Nr.
500 104 ...
Figur-Nr. / Shape #
ø 1/10 mm
VE / packaging unit

superfein, gelber Ring / superfine, yellow ring

TITANO
15' - 30000 Upm/rpm

141	198	200	237	275	292
023	018	040	023	060	023
1	1	1	1	1	1

705102SF
704902SF
700801SF
704602SF
708001SF
702602SF

Order-Nr.

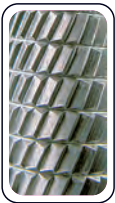

Verzahnung / Crosscut
ISO 176
ISO-Nr.
500 104 ...
Figur-Nr. / Shape #
ø 1/10 mm
VE / packaging unit

ultrafein, weißer Ring / ultrafine, white ring

STAR
15' - 30000 Upm/rpm

141	185	198	198	199	200	237	275	289	290
023	023	018	023	023	040	023	060	023	023
1	1	1	1	1	1	1	1	1	1

702402
702102
704902
704802
702202
700801
704602
708001
705002
702602

Order-Nr.

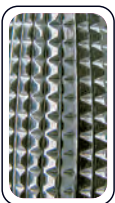

Verzahnung / Crosscut
ISO 132
ISO-Nr.
500 104 ...
Figur-Nr. / Shape #
ø 1/10 mm
VE / packaging unit

ultrafein, weißer Ring / ultrafine, white ring

SUPER-STAR
15' - 30000 Upm/rpm

199	200	275	292
023	040	060	023
1	1	1	1

712202SF
710801SF
718001SF
712602SF

Order-Nr.

Anwendung/Application



- Titan
Titanium
- NE-Legierungen
Non-precious alloys
- Komposite
Composites
- Lichthärtendes Löffelmaterial
Light-curing tray material



- Edelmetall-Legierungen
Precious alloys
- Extraharte Verblendkunststoffe
Tough acrylic veneers
- Titan
Titanium

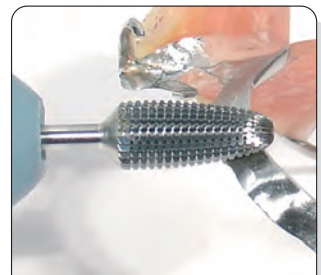

- NE-Legierungen
Non-precious alloys
- Komposite
Composites
- Weichbleibende Kunststoffe
Soft lining material

DIADUR BlueStar® Hartmetallfräser / DIADUR BlueStar® carbide cutters

Extrem glatte Beschichtung mit Supernitriden der neuesten Generation.
 Deutlich erhöhte Standzeit gegenüber herkömmlichen Beschichtungen, signifikante Reduzierung des Reibungswiderstands bei gleichbleibender Aggressivität, weiches Fräsgefühl.

*Extremely smooth coating using the newest generation of supernitrides.
 Significantly increased lifetime compared to conventional coatings, reduced friction resistance and improved cutting efficiency, smooth grinding.*



Verzahnung / Crosscut
 ISO 015
 ISO-Nr.
 507 104 ...
 Figur-Nr./Shape #
 ø 1/10 mm
 VE / packaging unit



fein, roter Ring / fine, red ring

MATRO
 15' - 30000 Upm/rpm

274	275
040	060
1	1

313301BS

313001BS

Order-Nr.

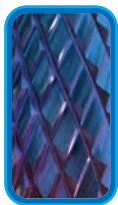

Verzahnung / Crosscut
 ISO 190
 ISO-Nr.
 507 104 ...
 Figur-Nr. / Shape #
 ø 1/10 mm
 VE / packaging unit



mittel, blauer Ring / medium, blue ring

QUATTRO
 15' - 30000 Upm/rpm

001	200	200	201	274	275
050	023	040	060	040	060
1	1	1	1	1	1

605201BS

606102BS

606801BS

607501BS

603301BS

602001BS

Order-Nr.

Anwendung / Application

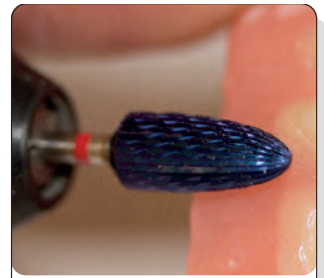

- Prothesen-Kunststoff
Heat, self and light curing acrylics
- Weichbleibende Kunststoffe
Soft lining material
- Valplast u.ä.
Valplast and similar



- Co-Cr Legierungen
Cobalt chrome alloys
- NE-Legierungen
Non-precious alloys
- Edelmetall-Legierungen
Precious alloys
- Reduzierte-Edelmetall-Legierungen
Semi-precious alloys

DIADUR BlueStar® Hartmetallfräser / DIADUR BlueStar® carbide cutters



Verzahnung / Crosscut
 ISO 134
 ISO-Nr.
 507 104 ...
 Figur-Nr./Shape #
 ø 1/10 mm
 VE / packaging unit

fein, roter Ring / fine, red ring

	NUEVO		
	15' - 30000 Upm/rpm		
Figur-Nr./Shape #	200	274	277
ø 1/10 mm	040	040	060
VE / packaging unit	1	1	1

740801FBS
743301FBS
747301FBS

Anwendung/Application

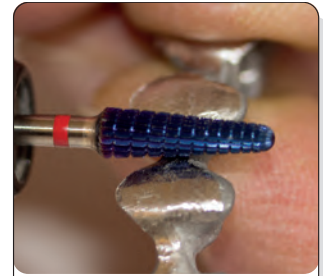

- Kunststoff (inkl. Valplast)
Acrylics (incl. Valplast)
- NE-Legierungen
Non-precious alloys
- Weichbleibende Kunststoffe
Soft lining materials

Order-Nr.

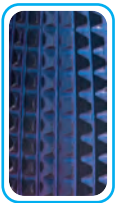

Verzahnung / Crosscut
 ISO 132
 ISO-Nr.
 507 104 ...
 Figur-Nr./Shape #
 ø 1/10 mm
 VE / packaging unit

ultrafein, weißer Ring / ultrafine, white ring

	SUPER-STAR	
	15' - 30000 Upm/rpm	
Figur-Nr./Shape #	200	275
ø 1/10 mm	040	060
VE / packaging unit	1	1

710801SFBS
718001SFBS

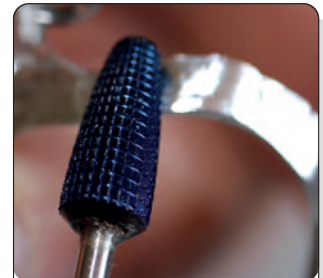

- NE-Legierungen
Non-precious alloys
- Komposite
Composites
- Weichbleibende Kunststoffe
Soft lining material

Order-Nr.

DIADUR Okklu-Point



Verzahnung / Cut
 ISO 377
 ISO-Nr.
 500 104 ... / 314 ...
 Figur-Nr. / Shape #
 ø 1/10 mm
 VE / packaging unit

kein Ring / without ring	
OKKLU-POINT 5' - 20000 Upm/rpm	OKKLU-POINT FG - 300000 Upm/rpm
470	470
010	010
2	5
80032	80044

Order-Nr.

Anwendung / Application

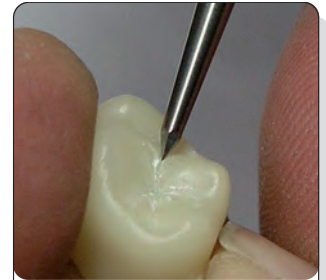

- Hartmetallinstrument zum Nachziehen keramischer Fissuren
 Carbide tool for occlusal ceramic fissures

Finierer / Finisher



ISO-Nr.
 314 104 ...
 Figur-Nr. / Shape #
 ø 1/10 mm
 VE / packaging unit

superfein / superfine	
FIPOL 10' - 30000 Upm/rpm	
272	
014	
3	
1011068	

Order-Nr.

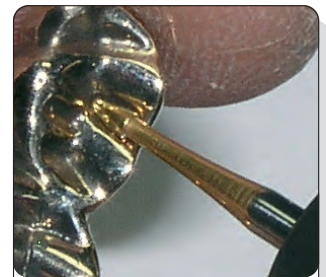

- Zum Hochglanzpolieren der finierten Fissuren bei Edelmetall (ohne Verzahnung)
 For high shine polishing of the fissures on precious metals (no cut)
- gehärteter Werkzeugstahl
 hardened steel

Stahlinstrumente / Steel burs



Verzahnung / Cut
 ISO 172
 ISO-Nr.
 330 104 ...
 Figur-Nr. / Shape #
 ø 1/10 mm
 VE / packaging unit

kein Ring / without ring			
SOFT LINER 5' - 20000 Upm/rpm			
001	155	266	266
050	060	045	055
1	1	1	1
311-0505L	312-0605L	310-0455L	310-0555L

Order-Nr.



- Zum Bearbeiten von weichbleibenden Kunststoffen
 For working on soft lining material



1

Verzahnung / cut
 ISO 006
 ISO-Nr. 500 104 ...
 Figur-Nr. / Shape No
 ø 1/10 mm
 KL / hl
 US-Code:
 VE / packaging unit

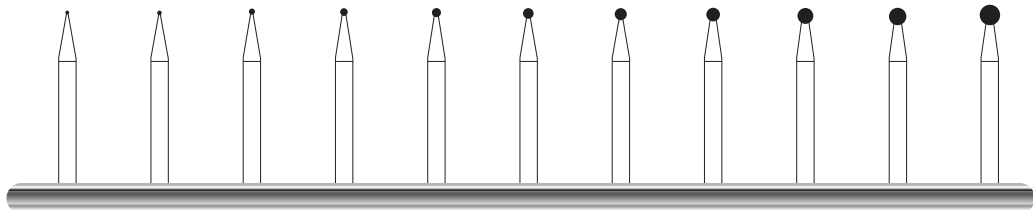

Rosenbohrer / Rosehead burs · 15' - 30000 Upm/rpm

001	001	001	001	001	001	001	001	001	001	001
005	006	008	010	012	014	016	018	021	023	027
-	-	-	-	-	-	-	-	-	-	-
1/4	1/2	1	2	3	4	5	6	7	8	10
6	6	6	6	6	6	6	6	6	6	6
117005	117006	117008	117010	117012	117014	117016	117018	117021	117023	117027

Order-Nr.



1



Verzahnung / cut
 ISO 291
 ISO-Nr. 500 104 ...
 Figur-Nr. / Shape No
 ø 1/10 mm
 KL / hl
 US-Code:
 VE / packaging unit

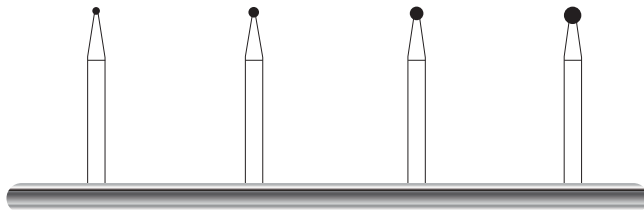

Rosenbohrer / Rosehead burs · 15' - 30000 Upm/rpm

001	001	001	001
010	014	018	023
-	-	-	-
2	4	6	8
6	6	6	6
117110	117114	117118	117123

Order-Nr.



2

Verzahnung / cut
 ISO 006
 ISO-Nr. 500 104 ...
 Figur-Nr. / Shape No
 ø 1/10 mm
 KL / hl
 US-Code:
 VE / packaging unit

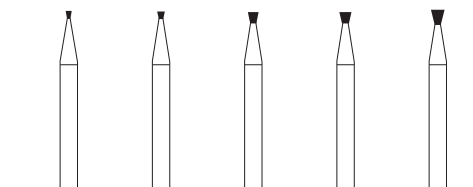

Kegelbohrer / Inverted cone burs
 15' - 30000 Upm/rpm

010	010	010	010	010
008	010	014	016	018
1,0	1,0	1,5	1,5	2
34	35	37	38	39
6	6	6	6	6
113008	113010	113014	113016	113018

Order-Nr.



3

Verzahnung / cut
 ISO 175
 ISO-Nr. 500 104 ...
 Figur-Nr. / Shape No
 ø 1/10 mm
 KL / hl
 US-Code:
 VE / packaging unit

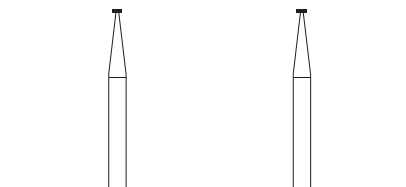

Radbohrer / Wheel burs
 15' - 30000 Upm/rpm

237	237
012	014
0,5	0,5
14	15
6	6
114012	114014

Order-Nr.



21

Verzahnung / cut
 ISO 006
 ISO-Nr. 500 104 ...
 Figur-Nr. / Shape No
 ø 1/10 mm
 KL / hl
 US-Code:
 VE / packaging unit

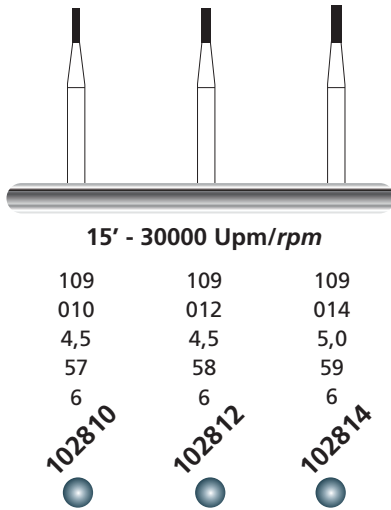

Order-Nr.



21R

Verzahnung / cut
 ISO 006
 ISO-Nr. 500 104 ...
 Figur-Nr. / Shape No
 ø 1/10 mm
 KL / hl
 US-Code:
 VE / packaging unit

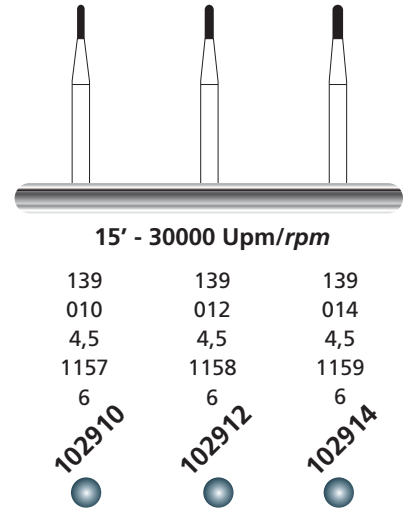

Order-Nr.



23

Verzahnung / cut
 ISO 006
 ISO-Nr. 500 104 ...
 Figur-Nr. / Shape No
 ø 1/10 mm
 KL / hl
 US-Code:
 VE / packaging unit

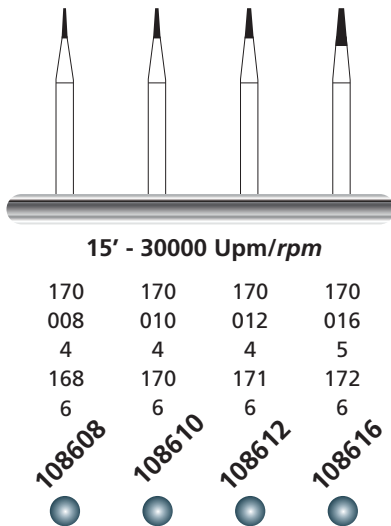

Order-Nr.



23L

Verzahnung / cut
 ISO 006
 ISO-Nr. 500 104 ...
 Figur-Nr. / Shape No
 ø 1/10 mm
 KL / hl
 US-Code:
 VE / packaging unit

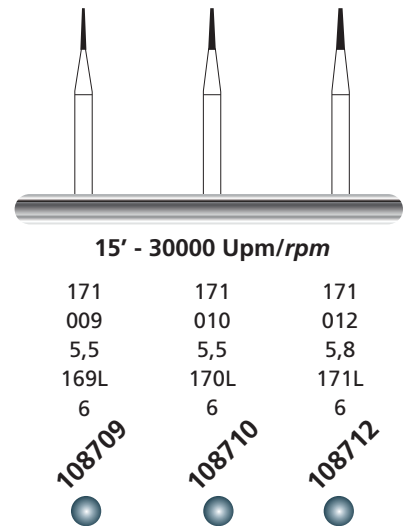

Order-Nr.



23R

Verzahnung / cut
 ISO 006
 ISO-Nr. 500 104 ...
 Figur-Nr. / Shape No
 ø 1/10 mm
 KL / hl
 US-Code:
 VE / packaging unit

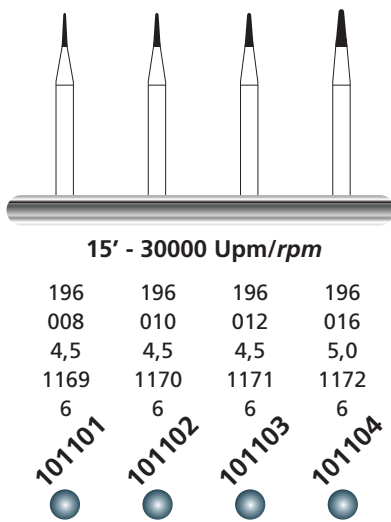

Order-Nr.



31

Verzahnung / cut
 ISO 008
 ISO-Nr. 500 104 ...
 Figur-Nr. / Shape No
 ø 1/10 mm
 KL / hl
 US-Code:
 VE / packaging unit

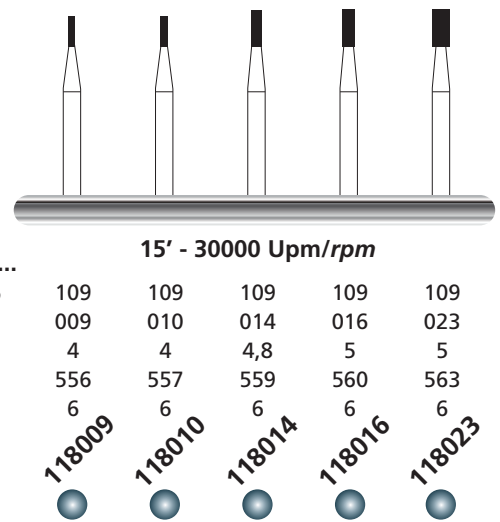

Order-Nr.



31L

Verzahnung / cut
 ISO 008
 ISO-Nr. 500 104 ...
 Figur-Nr. / Shape No
 ø 1/10 mm
 KL / hl
 US-Code:
 VE / packaging unit

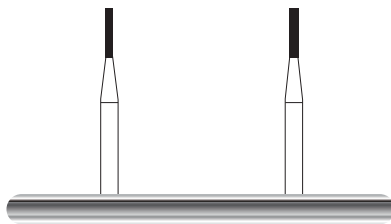

15' - 30000 Upm/rpm

110	110
010	012
6,5	6,5
557L	558L
6	6

108810

108812

Order-Nr.



31R

Verzahnung / cut
 ISO 008
 ISO-Nr. 500 104 ...
 Figur-Nr. / Shape No
 ø 1/10 mm
 KL / hl
 US-Code:
 VE / packaging unit

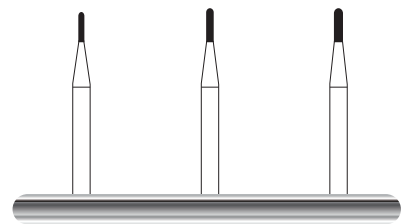

15' - 30000 Upm/rpm

139	139	139
008	010	012
4	4,5	4,5
1556	1557	1558
6	6	6

108908

108910

108912

Order-Nr.



33

Verzahnung / cut
 ISO 008
 ISO-Nr. 500 104 ...
 Figur-Nr. / Shape No
 ø 1/10 mm
 KL / hl
 US-Code:
 VE / packaging unit

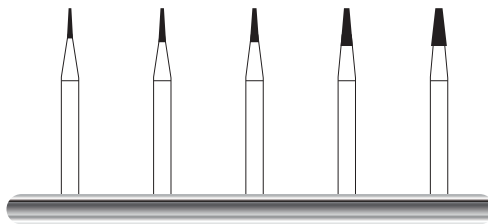

15' - 30000 Upm/rpm

170	170	170	170	170
008	010	012	016	021
4	4,5	4,5	5	5
699	700	701	702	703
6	6	6	6	6

109308

109310

109312

109316

109321

Order-Nr.



33L

Verzahnung / cut
 ISO 008
 ISO-Nr. 500 104 ...
 Figur-Nr. / Shape No
 ø 1/10 mm
 KL / hl
 US-Code:
 VE / packaging unit

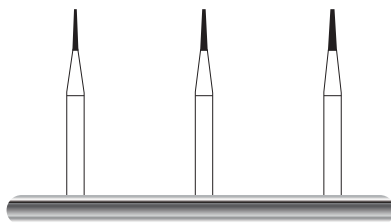

15' - 30000 Upm/rpm

171	171	171
008	010	012
5,5	5,5	5,5
699L	700L	701L
6	6	6

109408

109410

109412

Order-Nr.



33R

Verzahnung / cut
 ISO 008
 ISO-Nr. 500 104 ...
 Figur-Nr. / Shape No
 ø 1/10 mm
 KL / hl
 US-Code:
 VE / packaging unit

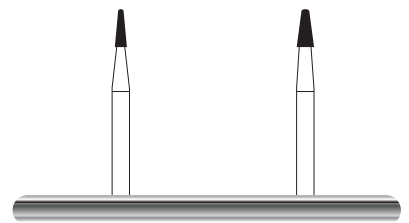

15' - 30000 Upm/rpm

196	196
016	023
5	5
1702	1705
6	6

109516

109523

Order-Nr.



Verzahnung / cut
ISO 134
ISO-Nr. 500 104 ...
 Figur-Nr. / Shape No
 ø 1/10 mm
 KL / h/
 US-Code:
 VE / packaging unit

OKKLU-STAR · 15' - 30000 Upm/rpm

277
 014
 3
 7404X
 6

117210

Order-Nr.



Verzahnung / cut
ISO 140
ISO-Nr. 500 104 ...
 Figur-Nr. / Shape No
 ø 1/10 mm
 KL / h/
 US-Code:
 VE / packaging unit

OKKLU-FIN · 15' - 30000 Upm/rpm

247
 023
 4,3
 7408X
 6

304402

Order-Nr.



Verzahnung / cut
ISO 072
ISO-Nr. 500 104 ...
 Figur-Nr. / Shape No
 ø 1/10 mm
 KL / h/
 US-Code:
 VE / packaging unit

Finierfräser / Finishing burs · 15' - 30000 Upm/rpm

254
 014
 3,5
 7104
 6

118070

277
 014
 3,5
 7404
 6

118080

296
 010
 4,0
 770
 6

118050

496
 010
 4,0
 7902
 6

118060

Order-Nr.

Ihre Vorteile / Benefits and advantages:

- Fast **doppelte Standzeit** gegenüber **herkömmlichen** Sinterdiamanten aufgrund höherer Diamantkonzentration
Almost double lifetime compared to traditional sintered diamonds due to increased diamond concentration
- Hohe Schneidleistung und Selbstreinigung
Efficient cutting and self-cleaning
- Schnellerer Abtrag
Faster abrasion
- Je nach Durchmesser 200-300 fach längere Standzeit gegenüber Schleifsteinen
Depending on diameter, our sintered diamonds are 200-300 times more durable than conventional stones
- **Zeitgewinn** durch weniger Werkzeugwechsel sowie reduzierte Lagerkosten, da weniger Werkzeuge notwendig sind
Increased productivity due to minimized instrument changes and reduced inventory (fewer instruments needed)
- **Umweltfreundlich**, wesentlich geringerer Rohstoffverbrauch und weniger Abfall
Environmentally friendly, substantially reduced waste and residue
- **Gesundes Arbeitsumfeld** aufgrund wesentlich geringerer Staubentwicklung als bei Schleifsteinen
Healthier work environment due to reduced dust compared to finishing stones



200 - 300 fache Standzeit gegenüber Schleifsteinen

200 - 300 times more durable than finishing stones

**Mit TITANIT
With TITANIT**

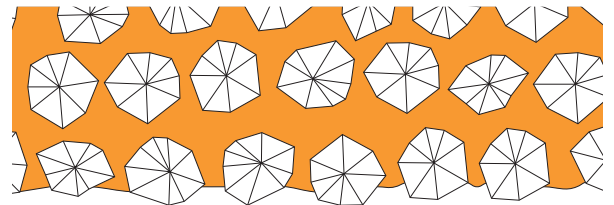

Oberflächenstruktur / Surface structure

Bei Sinterdiamanten (Bindemittel Bronze mit Tantal u.a.) schleift sich das Bindemittel durch die Reibung automatisch weg. Bei verbrauchter äußerer Schicht steht die folgende Diamantschicht zum Schleifen bereit.

Empfehlung:

Nicht auf zur Keramikverblendung vorgesehenen Flächen einsetzen.

The high concentration of diamonds in SIDIA® sintered diamonds and the unique bonding consisting of bronze, tantal and others ensures continuous quality finishing for the entire lifetime of the instrument. Recommendation: do not use on bonding areas.

SIDIA® Sinterdiamanten / SIDIA® sintered diamonds

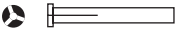
FG HP

Inklusive Reduzierstück
 Included free in each package!

Körnung / grit size
 ISO 523
 ISO-Nr.
 807 314 ...

Figur-Nr. / Shape #
 ø 1/10 mm
 VE / packaging unit



mittel, blauer Ring / medium, blue ring

	112	142	199	237	250
Figur-Nr. / Shape #	016	016	016	016	016
VE / packaging unit	1	1	1	1	1

FG MACRO
 30' - 300000 Upm/rpm

Order-Nr. 56262 56212 56242 56252 56202

Anwendung / Application

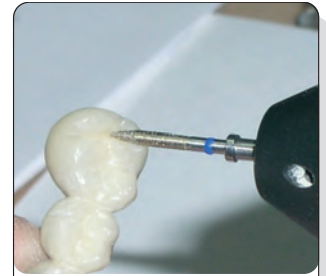

• Keramik
 Ceramics

FG HP

Inklusive Reduzierstück
 Included free in each package!

Körnung / grit size
 ISO 513
 ISO-Nr.
 807 314 ...

Figur-Nr. / Shape #
 ø 1/10 mm
 VE / packaging unit



fein, roter Ring / fine, red ring

	112	142	199	250
Figur-Nr. / Shape #	016	016	016	016
VE / packaging unit	1	1	1	1

FG MICRO
 30' - 300000 Upm/rpm

Order-Nr. 52262 52212 52242 52202



• Keramik
 Ceramics

Körnung / grit size
 ISO 523
 ISO-Nr.
 807 104 ...

Figur-Nr. / Shape #
 ø 1/10 mm
 VE / packaging unit



mittel, blauer Ring / medium, blue ring

	131	142	199	225	250
Figur-Nr. / Shape #	016	016	016	016	016
VE / packaging unit	1	1	1	1	1

HP MACRO
 15' - 30000 Upm/rpm

Order-Nr. 58232 58212 58242 58272 58202



• Keramik
 Ceramics

SIDIA® Sinterdiamanten / SIDIA® sintered diamonds

Anwendung/Application



- Keramik
Ceramics

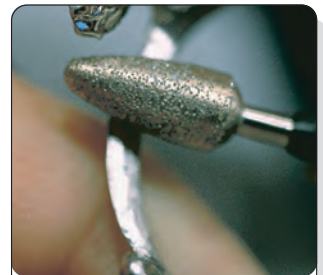

- Co-Cr Legierungen
Cobalt chrome alloys



- Co-Cr Legierungen
Cobalt chrome alloys
- NE-Legierungen
Non-precious alloys
- Reduzierte-Edelmetall-Legierungen
Semi-precious alloys

fein, roter Ring / fine, red ring

HP MICRO						
15' - 30000 Upm/rpm						
Figur-Nr./Shape #	112	131	142	199	225	250
ø 1/10 mm	016	016	016	016	016	016
VE/packaging unit	1	1	1	1	1	1

Order-Nr. 57262 57232 57212 57242 57272 57202

extragrob, schwarzer Ring / extracoarse, black ring

SUPERTURBO				
15' - 30000 Upm/rpm				
Figur-Nr./Shape #	042	112	161	275
ø 1/10 mm	100	050	050	060
VE/packaging unit	1	1	1	1

Order-Nr. 53305 53021 53181 53161

grob, grüner Ring / coarse, green ring

TURBO									
15' - 30000 Upm/rpm									
Figur-Nr./Shape #	001	112	161	199	200	249	257	274	275
ø 1/10 mm	030	050	050	050	040	030	060	050	060
VE/packaging unit	1	1	1	1	1	1	1	1	1

Order-Nr. 55122 55021 55181 55630 55044 55092 55600 55620 55161

Körnung / grit size
ISO 513
ISO-Nr.
807 104 ...
Figur-Nr./Shape #
ø 1/10 mm
VE/packaging unit

Körnung / grit size
ISO 543
ISO-Nr.
807 104 ...
Figur-Nr./Shape #
ø 1/10 mm
VE/packaging unit

Körnung / grit size
ISO 533
ISO-Nr.
807 104 ...
Figur-Nr./Shape #
ø 1/10 mm
VE/packaging unit

SIDIA® Sinterdiamanten / SIDIA® sintered diamonds

Anwendung/Application

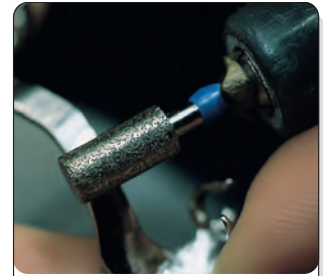

- Co-Cr Legierungen
Cobalt chrome alloys
- Keramik
Ceramics

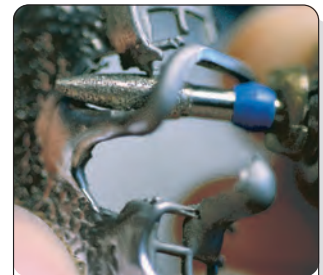

- Co-Cr Legierungen
Cobalt chrome alloys
- Keramik
Ceramics



- Co-Cr Legierungen
Cobalt chrome alloys
- Keramik
Ceramics

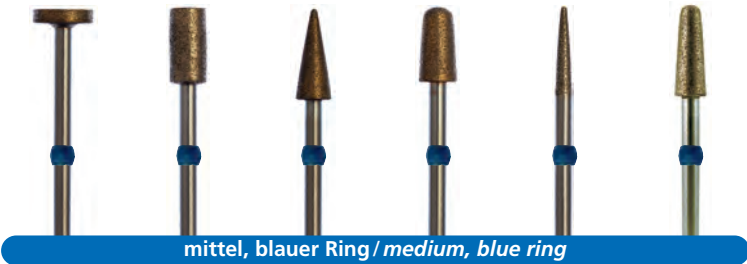

mittel, blauer Ring / medium, blue ring

Körnung / grit size
ISO 523
ISO-Nr.
807 104 ...
Figur-Nr. / Shape #
ø 1/10 mm
VE / packaging unit

MACRO
15' - 30000 Upm/rpm

042	112	161	199	200	200
080	050	050	050	023	040
1	1	1	1	1	1

Order-Nr.

- 59800
- 59021
- 59181
- 59630
- 59202
- 59205

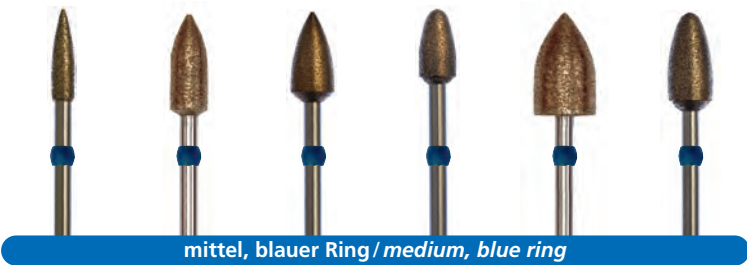

mittel, blauer Ring / medium, blue ring

Körnung / grit size
ISO 523
ISO-Nr.
807 104 ...
Figur-Nr. / Shape #
ø 1/10 mm
VE / packaging unit

MACRO
15' - 30000 Upm/rpm

249	251	257	274	274	275
030	050	060	050	080	060
1	1	1	1	1	1

Order-Nr.

- 59092
- 59151
- 59600
- 59620
- 59625
- 59161



fein, roter Ring / fine, red ring

Körnung / grit size
ISO 513
ISO-Nr.
807 104 ...
Figur-Nr. / Shape #
ø 1/10 mm
VE / packaging unit

MICRO
15' - 30000 Upm/rpm

001	001	001	012	014	014	014	023	027
023	030	040	030	040	060	080	027	027
1	1	1	1	1	1	1	1	1

Order-Nr.

- 50420
- 50122
- 50610
- 50112
- 50400
- 50650
- 50051
- 50215
- 50192

SIDIA® Sinterdiamanten / SIDIA® sintered diamonds

Anwendung/Application



- Co-Cr Legierungen
Cobalt chrome alloys
- Keramik
Ceramics



- Co-Cr Legierungen
Cobalt chrome alloys
- Keramik
Ceramics

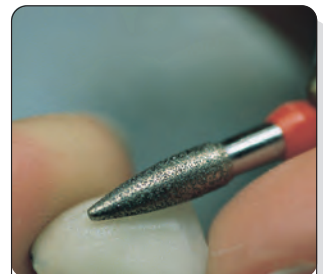

- Co-Cr Legierungen
Cobalt chrome alloys
- Keramik
Ceramics

fein, roter Ring / fine, red ring

MICRO
15' - 30000 Upm/rpm

040	042	111	112	143	155	161
050	080	030	050	025	030	025
1	1	1	1	1	1	1

Order-Nr. 50309 50800 50082 50021 50212 50072 50217

Körnung / grit size
ISO 513
ISO-Nr.
807 104 ...
Figur-Nr. / Shape #
ø 1/10 mm
VE / packaging unit

fein, roter Ring / fine, red ring

MICRO
15' - 30000 Upm/rpm

161	173	173	199	200	200	225	225
050	030	050	050	023	040	030	040
1	1	1	1	1	1	1	1

Order-Nr. 50181 50102 50041 50630 50202 50044 50172 50031

Körnung / grit size
ISO 513
ISO-Nr.
807 104 ...
Figur-Nr. / Shape #
ø 1/10 mm
VE / packaging unit

fein, roter Ring / fine, red ring

MICRO
15' - 30000 Upm/rpm

248	249	251	257	257	274	275	303
016	030	030	030	060	050	060	080
1	1	1	1	1	1	1	1

Order-Nr. 50310 50092 50214 50216 50600 50620 50161 50131

Körnung / grit size
ISO 513
ISO-Nr.
807 104 ...
Figur-Nr. / Shape #
ø 1/10 mm
VE / packaging unit

SIDIA® Sinterdiamanten / SIDIA® sintered diamonds

Anwendung/Application



- Co-Cr Legierungen
Cobalt chrome alloys
- Keramik
Ceramics

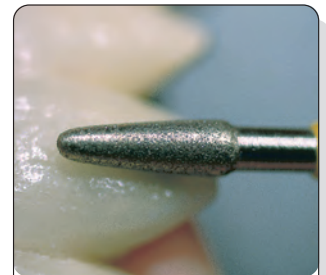

- Co-Cr Legierungen
Cobalt chrome alloys
- Keramik
Ceramics

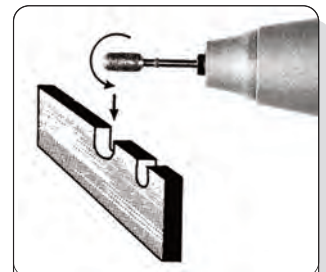

- Zum Reinigen von Sinter- und galvanischen Diamantwerkzeugen
Cleaning stone for sintered and electroplated diamonds
- Vor Benutzung anfeuchten
Apply water before using

Körnung / grit size
ISO 503
ISO-Nr.
807 104 ...
Figur-Nr. / Shape #
ø 1/10 mm
VE / packaging unit

superfein, gelber Ring / superfine, yellow ring			
MILLI-MICRON			
15' - 30000 Upm/rpm			
001	027	161	161
023	027	025	050
1	1	1	1
54420	54192	54217	54181

Order-Nr.

Körnung / grit size
ISO 503
ISO-Nr.
807 104 ...
Figur-Nr. / Shape #
ø 1/10 mm
VE / packaging unit

superfein, gelber Ring / superfine, yellow ring			
MILLI-MICRON			
15' - 30000 Upm/rpm			
198	199	257	275
030	016	030	060
1	1	1	1
54102	54242	54216	54161

Order-Nr.

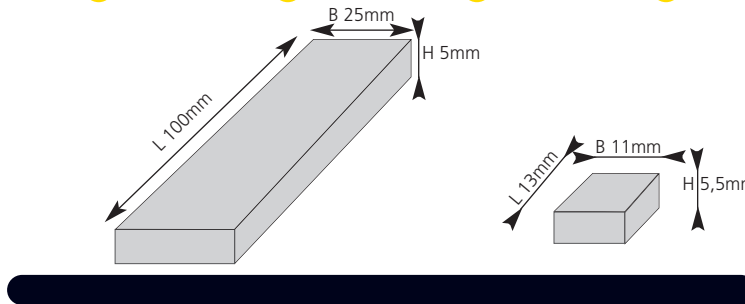

REINIGUNGSSTEINE / CLEANING STONES

VE / packaging unit

Order-Nr.

1	1
15000	15001

SIDIA® Sinterdiamantscheiben / SIDIA® sintered diamond discs

Körnung / grit size
 ISO 523
ISO-Nr.
807 104 ...
 Figur-Nr. / Shape #
 ø 1/10 mm
 VE / packaging unit

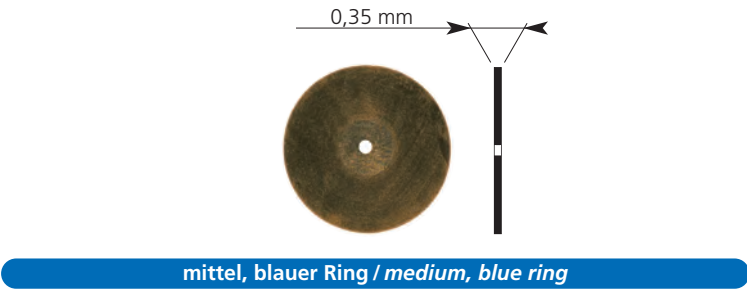

MACRO
 5' - 15000 Upm/rpm
 345
 220
 1

Order-Nr.

58154

Anwendung/Application



- Zum Kontourieren von CoCr-Legierungen
 For contouring of CoCr-alloys
- Alle Sinterdiamantscheiben sind montiert und zentriert
 All sintered diamond discs are mounted and centered

Körnung / grit size
 ISO 513
ISO-Nr.
807 104 ...
 Figur-Nr. / Shape #
 ø 1/10 mm
 VE / packaging unit

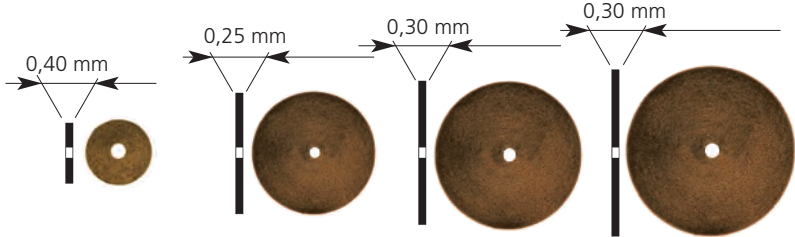

MICRO

	5' - 15000 Upm/rpm			
	345	345	345	345
	080	160	190	220
	1	1	1	1

Order-Nr.

50144

50265

50275

50154



- Zum Kontourieren von CoCr-Legierungen
 For contouring of CoCr-alloys
- Alle Sinterdiamantscheiben sind montiert und zentriert
 All sintered diamond discs are mounted and centered

Galvanische Sinterscheiben / Electroplated sintered diamond discs

Rand volldiamantiert und flexibel!
Flexible disc with true sintered diamond edge!

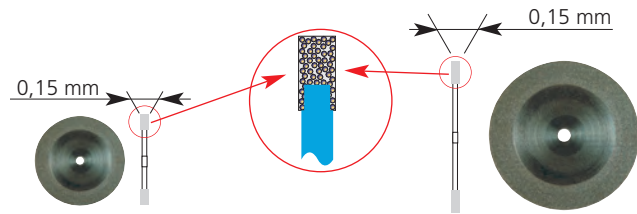

SIDIA®-MINI-FLEX **SIDIA®-FLEX**

3' - 5000 Upm/rpm

Körnung / grit size
 ISO 504
ISO-Nr.
807 104 ...
 Figur-Nr. / Shape #
 ø 1/10 mm
 VE / packaging unit

320
 120
 1

320
 200
 1

181221

182021

Order-Nr.



- Zum Trennen und Separieren von:
- Keramik inkl. Zirkon
 - Extrem hohe Standzeit
- For separating of:
- Ceramics incl zirconia
 - Extremely long lasting

Zirkonbearbeitung / Zirconia instruments

Körnung / grit size
ISO 534/524
ISO-Nr.
803 104...
 Figur-Nr./Shape #
 ø 1/10 mm
 VE / packaging unit

CIRCOOL LAB XL

5' - 25000 Upm/rpm	5' - 20000 Upm/rpm	5' - 25000 Upm/rpm	5' - 8000 Upm/rpm
112	013	173	042
036	060	035	130
1	1	1	1

Order-Nr. **800161** **800162** **800163** **800164**

Anwendung/Application



- Diamantschleifkörper speziell für die trockene, grobe Zirkonbearbeitung
 Diamond-impregnated tools for dry rough adjustment

Trockene Bearbeitung
No water cooling needed!

Körnung / grit size
ISO 534
ISO-Nr.
805 104...
 Figur-Nr./Shape #
 ø 1/10 mm
 VE / packaging unit

grob / coarse

CIRCOOL LAB

3' - 18000 Upm/rpm	3' - 4000 Upm/rpm	3' - 6000 Upm/rpm	3' - 5000 Upm/rpm
173	303	372	372
040	220	120	150
1	1	1	1

Order-Nr. **800140** **800148** **800142** **800146**



- Grobe Nachbearbeitung
 Rough adjustment work

Trockene Bearbeitung
No water cooling needed!

Körnung / grit size
ISO 524
ISO-Nr.
803 104 ...
 Figur-Nr./Shape #
 ø 1/10 mm
 VE / packaging unit

mittel / medium

CIRCOOL LAB

3' - 15000 Upm/rpm	3' - 15000 Upm/rpm	3' - 8000 Upm/rpm	3' - 10000 Upm/rpm
173	250	371	372
035	060	170	110
1	1	1	1

Order-Nr. **800133** **800135** **800137** **800131**

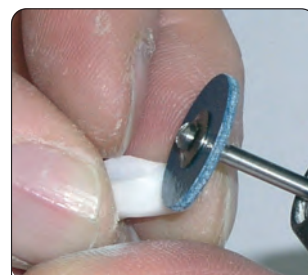

- Feine Nachbearbeitung
 Soft adjustment work
- Vorpolitur
 Prepolishing

Trockene Bearbeitung
No water cooling needed!

Zirkonbearbeitung / Zirconia instruments

Körnung / grit size
ISO 502
ISO-Nr.
803 104 ...
Figur-Nr. / Shape #
ø 1/10 mm
VE / packaging unit

superfein / superfine

CIRCOPOL LAB

3' - 15000 Upm/rpm	3' - 10000 Upm/rpm	
292	372	292/372
050	150	
1	1	je 1 St./1 pc each

800138 800136 800132

Order-Nr.

Anwendung/Application

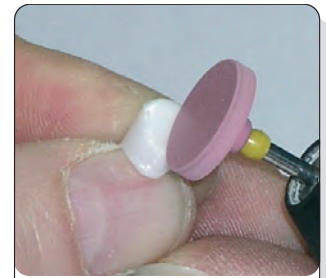

• Zirkon
Zirconia

**Trockene Bearbeitung
No water cooling needed!**

ISO-Nr.
807 314 / 806 315...
Figur-Nr. / Shape #
ø 1/10 mm
VE / packaging unit

fein, roter Ring / fine, red ring

SIDIA FG				FG Zirkondiamanten / FG Zirconia diamonds		
- 300000 Upm/rpm				- 300000 Upm/rpm		
112	142	199	237	142	199	277
016	016	016	016	014	016	012
1	1	1	1	3	3	3

52261 52211 52241 52251LA 532678L 531136L 532908L

Order-Nr.



• Zirkon
Zirconia

**Wasserkühlung!
Water cooling!**

Körnung / grit size
ISO 524
ISO-Nr.
807 104 ...
Figur-Nr. / Shape #
ø 1/10 mm
VE / packaging unit

ZIRKONDIAMANTEN HST / HP ZIRCONIA DIAMONDS

5' - 30000 Upm/rpm

112	143	199	257
018	018	016	023
2	2	2	2

60112188Syn 60143188Syn 60199168Syn 60257238Syn

Order-Nr.



• Zirkon
Zirconia

**Wasserkühlung!
Water cooling!**

Zirkonbearbeitung / Zirconia instruments

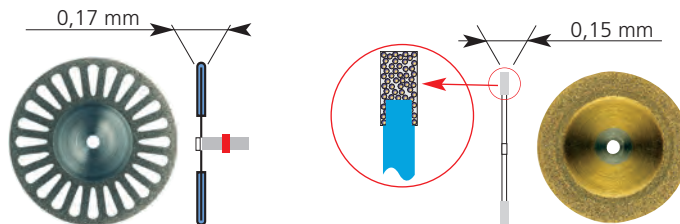

Körnung / grit size
ISO 514 / 504
ISO-Nr.
806 / 807 104...
Figur-Nr. / Shape #
ø 1/10 mm
VE / packaging unit

fein, roter Ring / fine, red ring

superfein, gelber Ring / superfine, yellow ring

SEPAFLEX®
3' - 5000 Upm/rpm
402
220
1

SIDIAFLEX GOLD
3' - 5000 Upm/rpm
320
200
1

182221Z

181220

Order-Nr.



Anwendung/Application



• Trennen der Verbindungsstege
Cutting of connecting bars

Wasserkühlung!
Water cooling!

Höhere Standzeit aufgrund neuer Diamantierungstechnologie!
Galvanische Diamanten zum Parallelfraßen mit der Laborturbine.
Wasserkühlung erforderlich!

Longer lifetime due to new diamond coating technology!
Electroplated FG diamonds for parallel milling in hydro air carver.
Water cooling required!



ISO-Nr.
806 314...
Figur-Nr. / Shape #
ø 1/10 mm
VE / packaging unit

CIRCONE 0°
- 300.000 Upm/rpm
142
020
Set/Kit 6 St./pcs

CIRCONE 1°
- 300.000 Upm/rpm
199
023
Set/Kit 6 St./pcs

CIRCONE 2°
- 300.000 Upm/rpm
199
023
Set/Kit 6 St./pcs

538099

538199

200115

Order-Nr.



Set/Kit 0°
Blau/blue 538080
Rot/red 538040
Gelb/yellow 538015
Orange/orange 538008
Rosa/pink 538004

Set/Kit 1°
Blau/blue 538180
Rot/red 538140
Gelb/yellow 538115
Orange/orange 538108
Rosa/pink 538104

Set/Kit 2°
Blau/blue 537580
Rot/red 537540
Gelb/yellow 537515
Orange/orange 537508
Rosa/pink 537504

Zirkonbearbeitung / Zirconia instruments



01	182221	3' - 5000	Upm/rpm
02	800163	5' - 25000	Upm/rpm
03	800164	5' - 8000	Upm/rpm
04	800131	3' - 10000	Upm/rpm
05	800137	3' - 8000	Upm/rpm
06	800136	3' - 10000	Upm/rpm
07	532908L	- 300000	Upm/rpm
08	532678L	- 300000	Upm/rpm

ZIRKONSET / ZIRCONIA KIT

800139

Order-Nr.

Sonderdiamantschleifer / Electroplated spiral diamond finishers

Körnung / grit size
ISO 544
ISO-Nr.
806 104 ...

Figur-Nr./Shape #
ø 1/10 mm
VE / packaging unit

Order-Nr.

extragrob, schwarzer Ring / extracoarse, black ring

LÖFFELRANDSCHLEIFER
PERIPHERY FINISHER

5' - 15000 Upm/rpm

060
1
60016

ALVEOLARSCHLEIFER
ALVEOLAR FINISHER

060
1
60015

Anwendung/Application

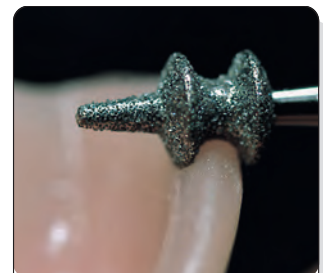

- Kunststoffe
Acrylics
- Lichthärtende Löffelmaterialien
Light curing tray materials

Körnung / grit size
ISO 544
ISO-Nr.
806 104 ...

Figur-Nr./Shape #
ø 1/10 mm
VE / packaging unit

Order-Nr.

extragrob, schwarzer Ring / extracoarse, black ring

PINFIX

5' - 15000 Upm/rpm

490
053
1
60017

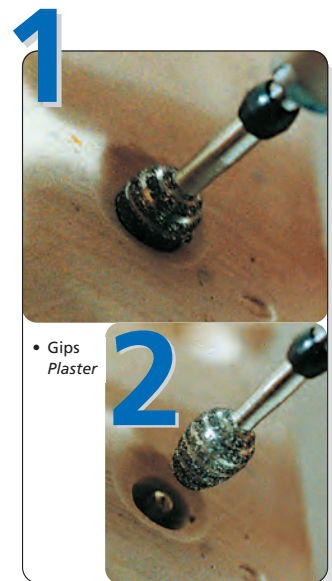

- Gips
Plaster

Sonderdiamantschleifer / Electroplated spiral diamond finishers

Körnung / grit size
ISO 544
ISO-Nr.
806 104 ...
 Figur-Nr. / Shape #
 ø 1/10 mm
 VE / packaging unit

extragrob, schwarzer Ring / extracoarse, black ring

	MINI	PLASTURBO	MAXI
		5' - 10000 Upm/rpm	
Figur-Nr. / Shape #	001		001
ø 1/10 mm	025		035
VE / packaging unit	1		1

Order-Nr. 60028 60029

Anwendung/Application

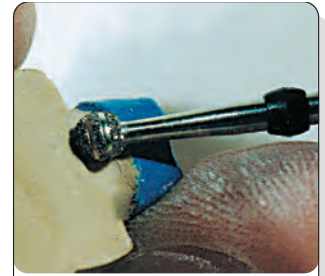

- **MINI** -> Zum zirkulären, schmierfreien Beschleifen der marginalen Präparationsstufe bei Frontstümpfen
 -> For grinding at the marginal line of incisive dies
- **MAXI** -> Zum zirkulären, schmierfreien Beschleifen der Molarenstümpfe
 -> For grinding at the surface of molar dies

Körnung / grit size
ISO 544
ISO-Nr.
806 104 ...
 Figur-Nr. / Shape #
 ø 1/10 mm
 VE / packaging unit

extragrob, schwarzer Ring / extracoarse, black ring

GUSSKANALSCHLEIFER / SPRUE FINISHER
 10' - 20000 Upm/rpm

Figur-Nr. / Shape #	076
ø 1/10 mm	130
VE / packaging unit	1

Order-Nr. 60052



- Co-Cr Legierungen
 Cobalt chrome alloys
- NE Legierungen
 Non-precious alloys

Körnung / grit size
ISO 544
ISO-Nr.
806 104 ...
 Figur-Nr. / Shape #
 ø 1/10 mm
 VE / packaging unit

extragrob, schwarzer Ring / extracoarse, black ring

TURBO DIAMANTSCHLEIFER / TURBO DIAMOND GRINDERS
 3' - 15000 Upm/rpm

Figur-Nr. / Shape #	200	200	200	201	237	274	291
ø 1/10 mm	027	043	063	027	063	063	027
VE / packaging unit	1	1	1	1	1	1	1

Order-Nr. 60022 60020 60024 60023 60027 60025 60021



- Ideal für weichbleibende Unterfütterungsmaterialien
 Ideal for soft relining materials
- Alle Kunststoffe
 All acrylics
- Gips
 Plaster
- Lichthärtendes Löffelmaterial
 Light curing tray material

Galvanische Diamantschleifer HST / Electroplated HP diamonds

Körnung / grit size
ISO 514 fein/fine
524 mittel/medium
544 extragrob/extracoarse
ISO-Nr.
806 104 ...
 Figur-Nr. / Shape #
 ø 1/10 mm
 KL/head length
 VE / packaging unit

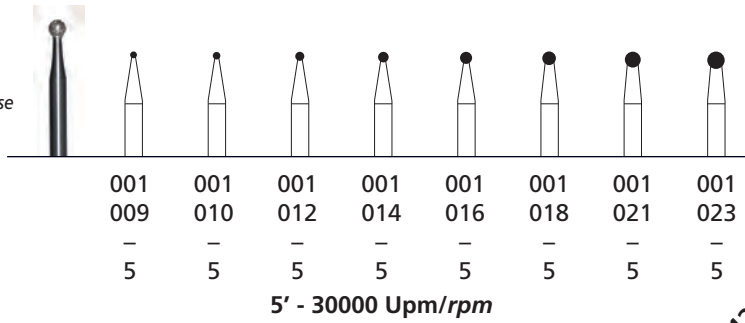

Order-Nr.

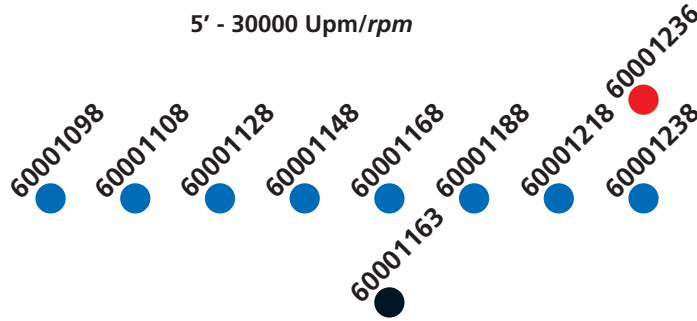

Anwendung/Application



- Keramik
Ceramics
- Harte Komposite
Hard composites

Körnung / grit size
ISO 524 mittel/medium
ISO-Nr.
806 104 ...
 Figur-Nr. / Shape #
 ø 1/10 mm
 KL/head length
 VE / packaging unit

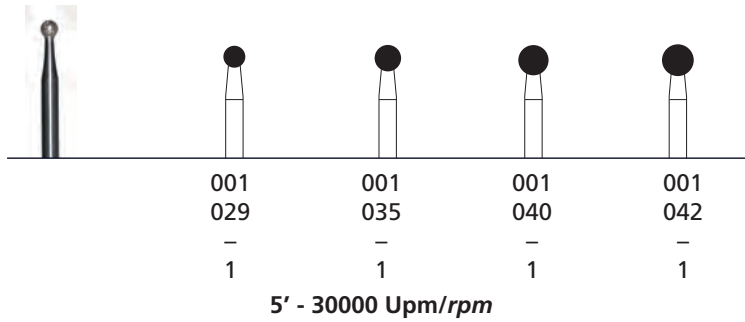

Order-Nr.



- Keramik
Ceramics
- Harte Komposite
Hard composites

Körnung / grit size
ISO 524 mittel/medium
ISO-Nr.
806 104 ...
 Figur-Nr. / Shape #
 ø 1/10 mm
 KL/head length
 VE / packaging unit

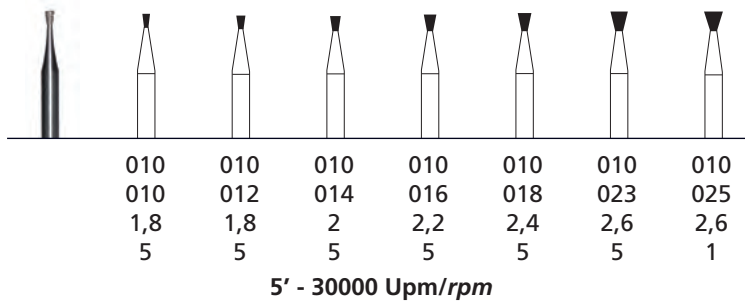

Order-Nr.



- Keramik
Ceramics
- Harte Komposite
Hard composites

Galvanische Diamantschleifer HST / Electroplated HP diamonds

Körnung / grit size
ISO **524** mittel/medium

ISO-Nr.
806 104 ...

Figur-Nr./Shape #
ø 1/10 mm
KL/head length
VE / packaging unit

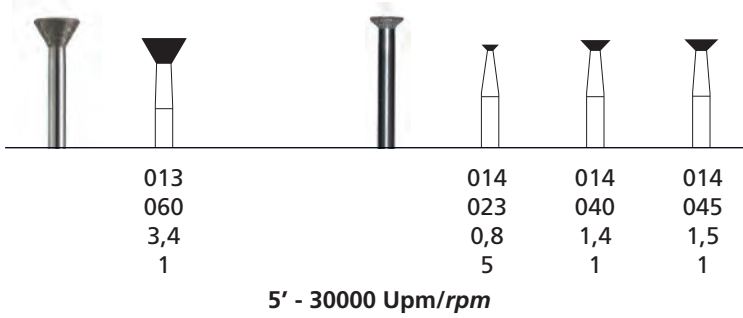

Order-Nr.

60013608

60014238

60014408

60014458

Anwendung/Application

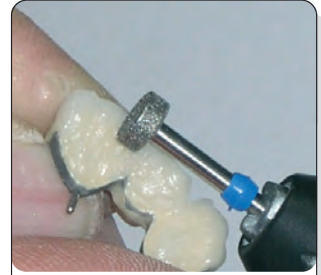

- Keramik
Ceramics
- Harte Komposite
Hard composites

Körnung / grit size
ISO **524** mittel/medium

ISO-Nr.
806 104 ...

Figur-Nr./Shape #
ø 1/10 mm
KL/head length
VE / packaging unit

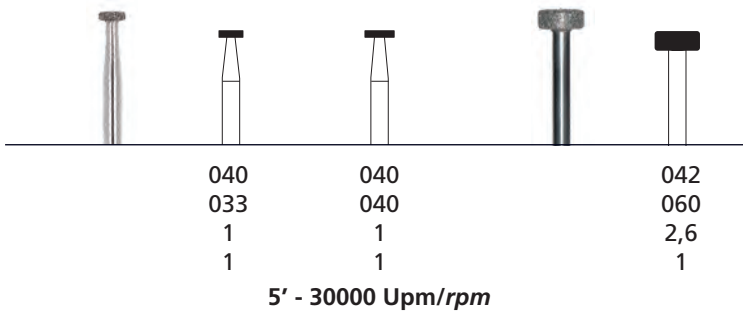

Order-Nr.

60040338

60040408

60042608



- Keramik
Ceramics
- Harte Komposite
Hard composites

Körnung / grit size
ISO **524** mittel/medium

ISO-Nr.
806 104 ...

Figur-Nr./Shape #
ø 1/10 mm
KL/head length
VE / packaging unit

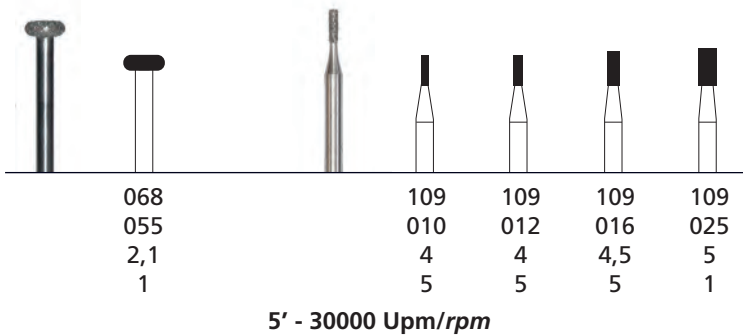

Order-Nr.

60068558

60109108

60109128

60109168

60109258



- Keramik
Ceramics
- Harte Komposite
Hard composites

Galvanische Diamantschleifer HST / Electroplated HP diamonds

Körnung / grit size
 ISO **524** mittel/medium
534 grob/coarse
 ISO-Nr.
806 104 ...
 Figur-Nr. / Shape #
 ø 1/10 mm
 KL/head length
 VE / packaging unit

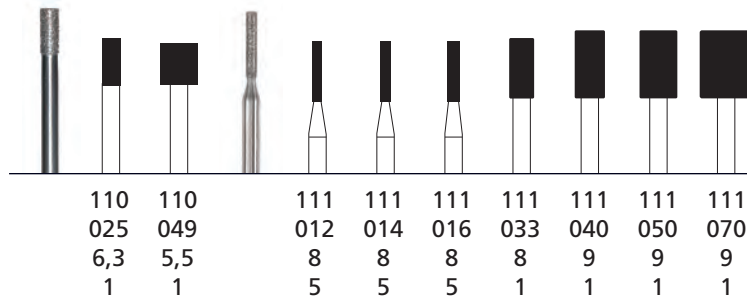

5' - 30000 Upm/rpm

- 60110258
- 60110498
- 60110495
- 60111128
- 60111148
- 60111168
- 60111338
- 60111408
- 60111508
- 60111708

Order-Nr.

Anwendung/Application



- Keramik
Ceramics
- Harte Komposite
Hard composites

Körnung / grit size
 ISO **514** fein/fine
524 mittel/medium
534 grob/coarse
 ISO-Nr.
806 104 ...
 Figur-Nr. / Shape #
 ø 1/10 mm
 KL/head length
 VE / packaging unit

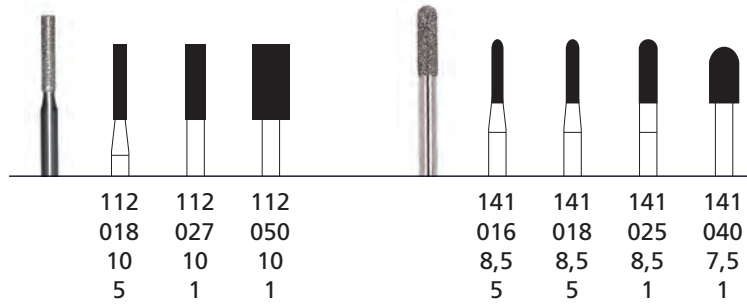

5' - 30000 Upm/rpm

- 60112186
- 60112188
- 60112276
- 60112278
- 60112508
- 60141168
- 60141188
- 60141185
- 60141256
- 60141258
- 60141408

Order-Nr.



- Keramik
Ceramics
- Harte Komposite
Hard composites

Körnung / grit size
 ISO **524** mittel/medium
534 grob/coarse
544 extragrob/extracoarse
 ISO-Nr.
806 104 ...
 Figur-Nr. / Shape #
 ø 1/10 mm
 KL/head length
 VE / packaging unit

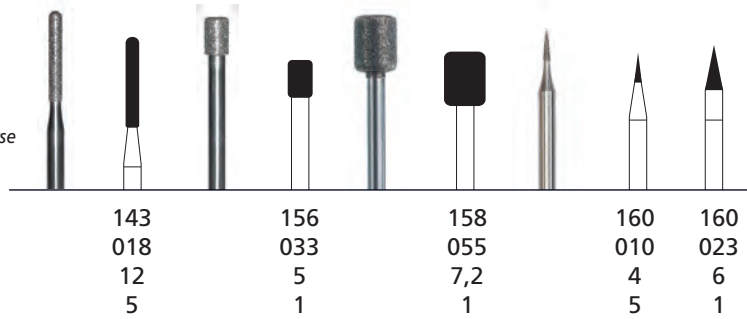

5' - 30000 Upm/rpm

- 60143188
- 60143183
- 60156338
- 60158558
- 60158555
- 60160108
- 60160238

Order-Nr.



- Keramik
Ceramics
- Harte Komposite
Hard composites

- Schwarz / Black
- Co-Cr-Legierungen
Co-Cr alloys

Galvanische Diamantschleifer HST / Electroplated HP diamonds

Körnung / grit size
 ISO **514** fein/fine
524 mittel/medium
 ISO-Nr.
806 104

Figur-Nr. / Shape #
 ø 1/10 mm
 KL/head length
 VE / packaging unit

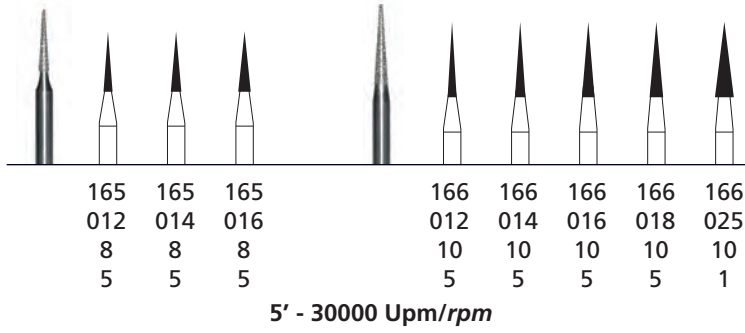

Order-Nr.

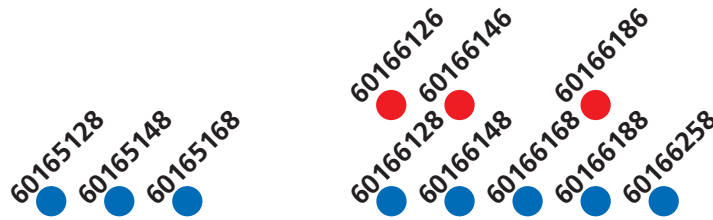

Anwendung/Application



- Keramik
Ceramics
- Harte Komposite
Hard composites

Körnung / grit size
 ISO **514** fein/fine
524 mittel/medium
 ISO-Nr.
806 104 ...

Figur-Nr. / Shape #
 ø 1/10 mm
 KL/head length
 VE / packaging unit

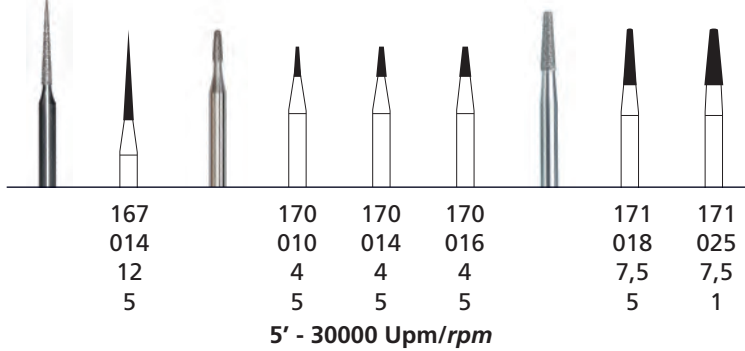

Order-Nr.

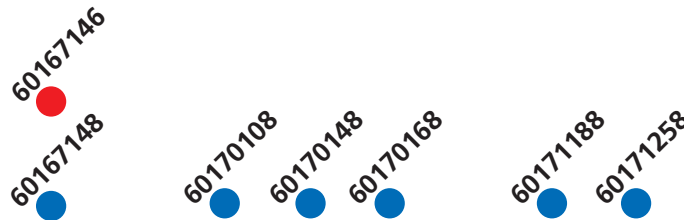

- Keramik
Ceramics
- Harte Komposite
Hard composites

Körnung / grit size
 ISO **514** fein/fine
524 mittel/medium
534 grob/coarse
544 extragrob/extracoarse
 ISO-Nr.
806 104 ...

Figur-Nr. / Shape #
 ø 1/10 mm
 KL/head length
 VE / packaging unit

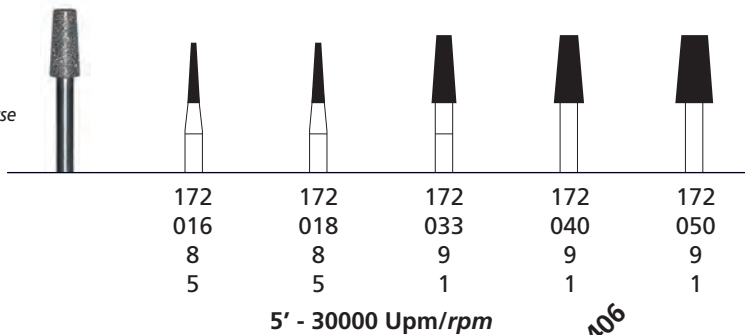

Order-Nr.

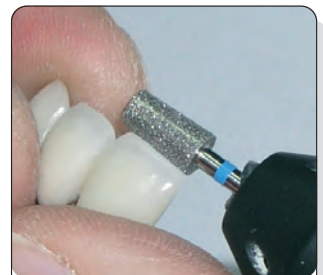
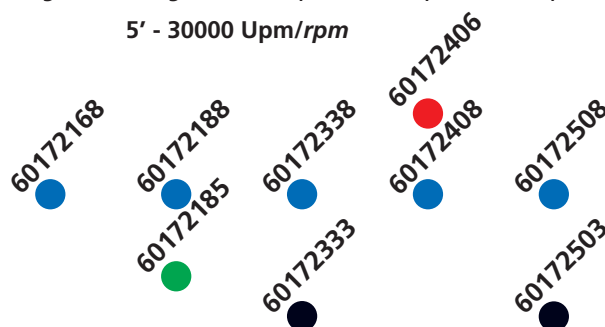

- Keramik
Ceramics
- Harte Komposite
Hard composites

Schwarz / Black
 • Co-Cr-Legierungen
Co-Cr alloys

Galvanische Diamantschleifer HST / Electroplated HP diamonds

Körnung / grit size
 ISO **514** fein/fine
524 mittel/medium
534 grob/coarse
 ISO-Nr.
806 104 ...
 Figur-Nr. / Shape #
 ø 1/10 mm
 KL/head length
 VE / packaging unit

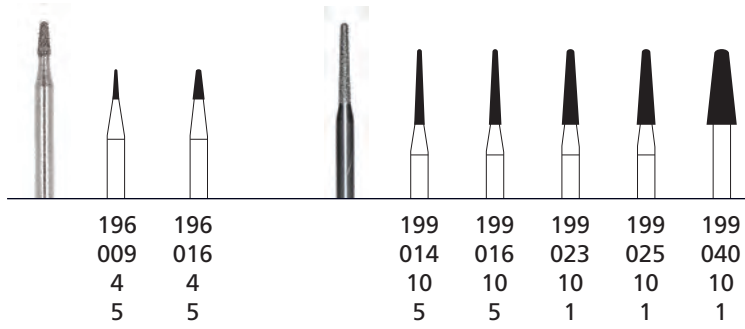

5' - 30000 Upm/rpm

Order-Nr.

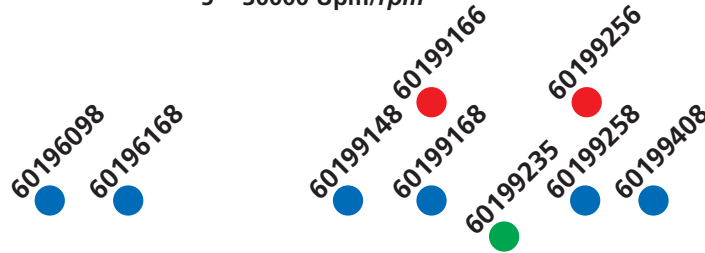

Anwendung/Application



- Keramik
Ceramics
- Harte Komposite
Hard composites

Körnung / grit size
 ISO **514** fein/fine
524 mittel/medium
 ISO-Nr.
806 104 ...
 Figur-Nr. / Shape #
 ø 1/10 mm
 KL/head length
 VE / packaging unit

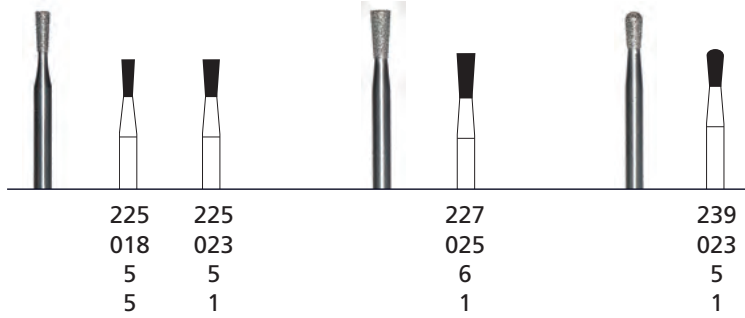

5' - 30000 Upm/rpm

Order-Nr.

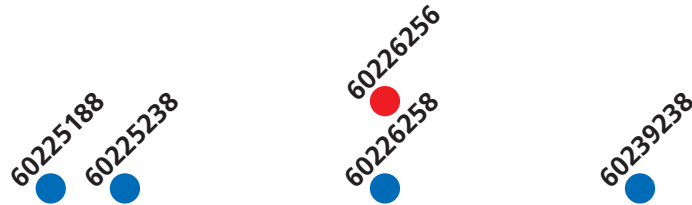

- Keramik
Ceramics
- Harte Komposite
Hard composites

Körnung / grit size
 ISO **514** fein/fine
524 mittel/medium
 ISO-Nr.
806 104 ...
 Figur-Nr. / Shape #
 ø 1/10 mm
 KL/head length
 VE / packaging unit

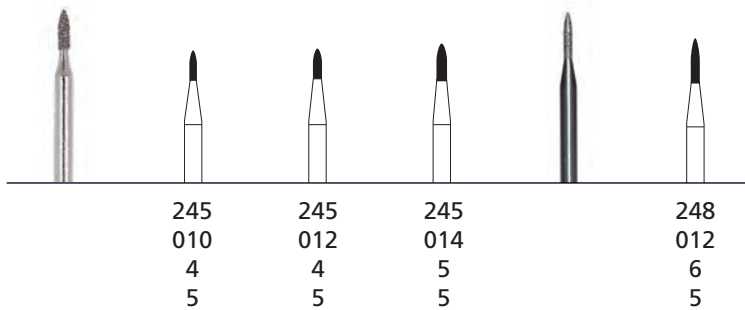

5' - 30000 Upm/rpm

Order-Nr.

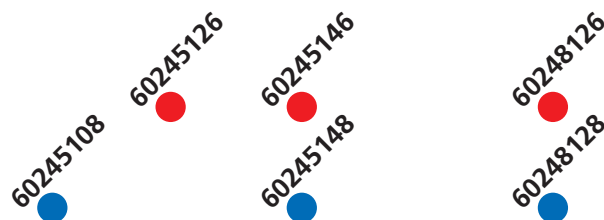

- Keramik
Ceramics
- Harte Komposite
Hard composites

Galvanische Diamantschleifer HST / Electroplated HP diamonds

Körnung / grit size
 ISO **514** fein/fine
524 mittel/medium
544 extragrob/extracoarse
 ISO-Nr.
806 104
 Figur-Nr. / Shape #
 ø 1/10 mm
 KL/head length
 VE / packaging unit

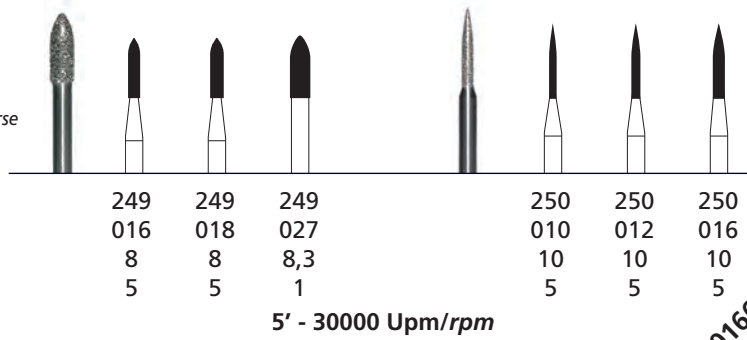

Order-Nr.

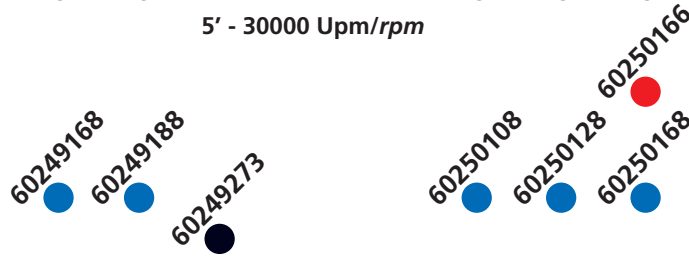

Anwendung/Application



- Keramik
Ceramics
 - Harte Komposite
Hard composites
- Schwarz / Black
- Co-Cr-Legierungen
Co-Cr alloys

Körnung / grit size
 ISO **514** fein/fine
524 mittel/medium
534 grob/coarse
 ISO-Nr.
806 104 ...
 Figur-Nr. / Shape #
 ø 1/10 mm
 KL/head length
 VE / packaging unit

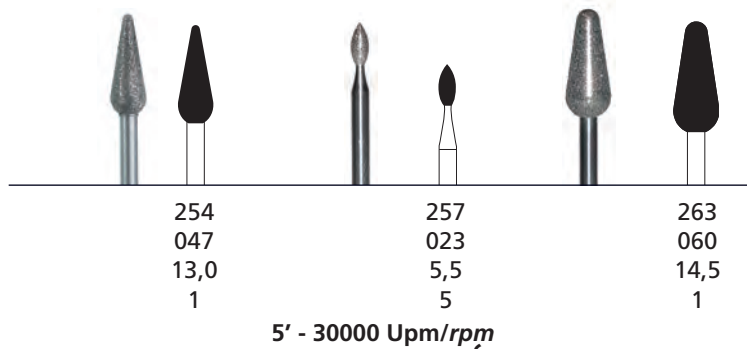

Order-Nr.

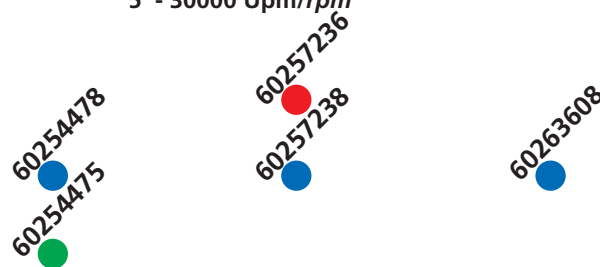

- Keramik
Ceramics
 - Harte Komposite
Hard composites
- Schwarz / Black
- Co-Cr-Legierungen
Co-Cr alloys

Körnung / grit size
 ISO **514** fein/fine
524 mittel/medium
544 extragrob/extracoarse
 ISO-Nr.
806 104 ...
 Figur-Nr. / Shape #
 ø 1/10 mm
 KL/head length
 VE / packaging unit

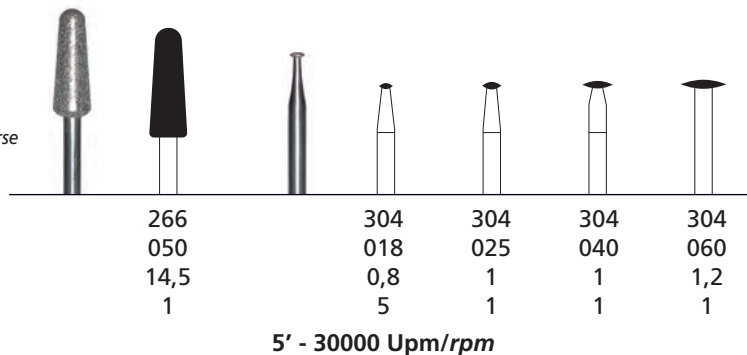

Order-Nr.

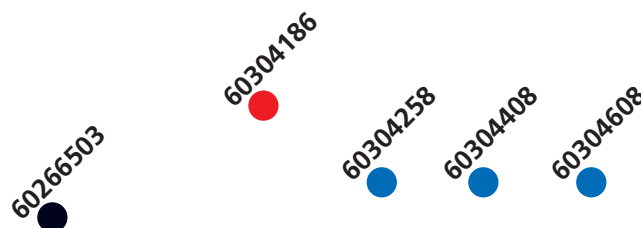

- Keramik
Ceramics
- Harte Komposite
Hard composites

Galvanische Diamantschleifer HST / Electroplated HP diamonds

Körnung / grit size
 ISO **514** fein/fine
524 mittel/medium
 ISO-Nr.
806 104 ...
 Figur-Nr./Shape #
 ø 1/10 mm
 KL/head length
 VE/packaging unit

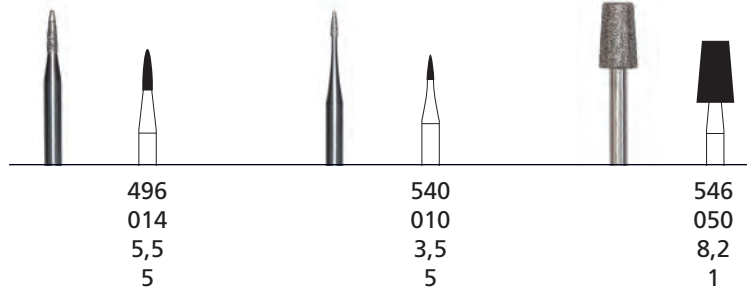

60496146
 60496148

5' - 30000 Upm/rpm

60540108

60546508

Order-Nr.

Anwendung/Application



- Keramik
Ceramics
- Harte Komposite
Hard composites

Keramikdiamanten XL HST in verdichteter Diamantierung / Electroplated HP diamonds XL in reinforced dense diamond coating

Körnung / grit size
 ISO **524** mittel/medium
 ISO-Nr.
806 104 ...
 Figur-Nr./Shape #
 ø 1/10 mm
 KL/head length
 VE/packaging unit

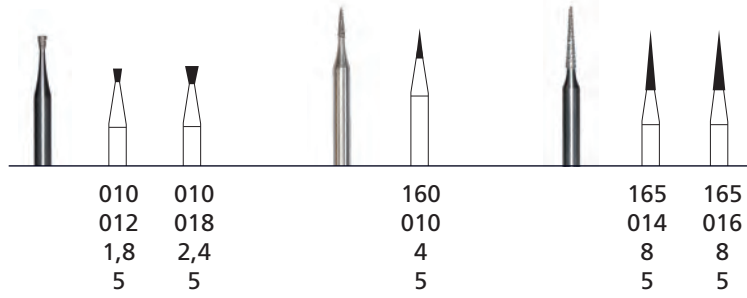

600101295
 600101895

5' - 30000 Upm/rpm

601601095

601651495
 601651695

Order-Nr.



- Keramik
Ceramics
- Harte Komposite
Hard composites

Körnung / grit size
 ISO **524** mittel/medium
 ISO-Nr.
806 104 ...
 Figur-Nr./Shape #
 ø 1/10 mm
 KL/head length
 VE/packaging unit

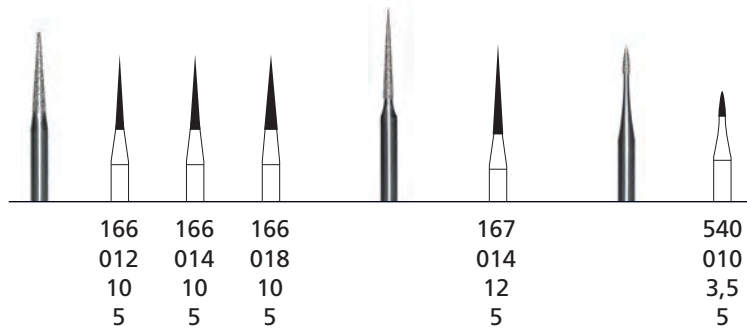

601661295
 601661495
 601661895

5' - 30000 Upm/rpm

601671495

605401095

Order-Nr.



- Keramik
Ceramics
- Harte Komposite
Hard composites

Bearbeitungsset für Lithium Disilikat Keramik / Tool set for lithium disilicate

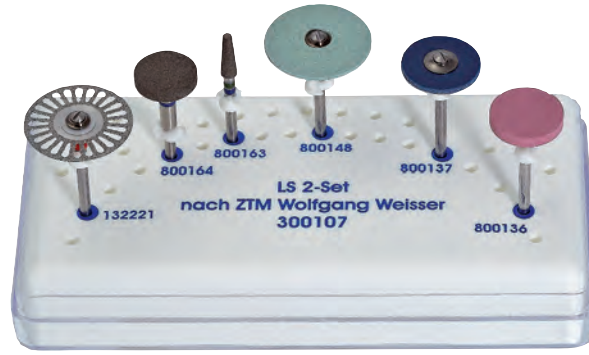

• Bearbeitungsset nach ZTM Wolfgang Weisser zur einfachen und schnellen Oberflächenbearbeitung vor dem finalen Brand.
Tool set according to DMT Wolfgang Weisser for easy and fast adjustment work of surfaces before final firing.

Inhalt:	Katalogseite
Content:	Catalog page
01 132221	41
02 800164	28
03 800163	28
04 800148	28
05 800137	28
06 800136	29

Order-Nr.

300107
O

Flexible Diamantscheiben / Flexible diamond discs



fein, roter Ring / fine, red ring

Körnung / grit size
 ISO 514
ISO-Nr. 806 104 ...
 Figur-Nr. / Shape #
 ø 1/10 mm
 VE / packaging unit

FIRMOFLEX
 5' - 10000 Upm/rpm
 355
 220
 1

Anwendung / Application

- Zum Separieren und Konturieren
For separation and contouring
- Keramik
Ceramics
- Komposite
Composites

Order-Nr.

172221

doppelseitig
 double sided

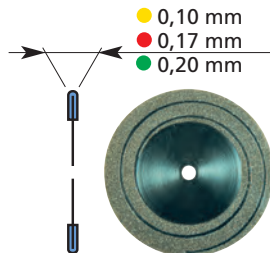

SPIROFLEX

Körnung / grit size
 ISO 504 + 514 + 534
ISO-Nr. 806 104 ...
 Figur-Nr. / Shape #
 ø 1/10 mm
 VE / packaging unit

SPIROFLEX
 5' - 10000 Upm/rpm
 355
 220
 1



- Keramik
Ceramics
- Komposite
Composites
- Kunststoff
Acrylics
- montiert und zentriert
mounted and centered
- auch unmontiert erhältlich
also available unmounted in bulk

Order-Nr.

122271

122291

122281

Flexible Diamantscheiben / Flexible diamond discs

doppelseitig
double sided

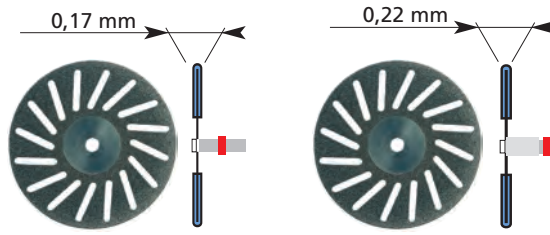

fein, roter Ring / fine, red ring

PLEXOFLEX
3' - 5000 Upm/rpm

389	390
220	220
1	1

162221

192221

Körnung / grit size
ISO 514
ISO-Nr.
806 104 ...
Figur-Nr. / Shape #
ø 1/10 mm
VE / packaging unit

Order-Nr.

Anwendung/Application

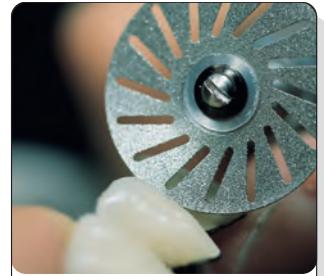

- Zum feinen Separieren und Konturieren
For delicate separation and contouring
- Keramik
Ceramics
- extraharte Verblendkunststoffe
Tough acrylic veneers
- montiert und zentriert
mounted and centered
- auch unmontiert erhältlich
also available unmounted in bulk

doppelseitig
double sided

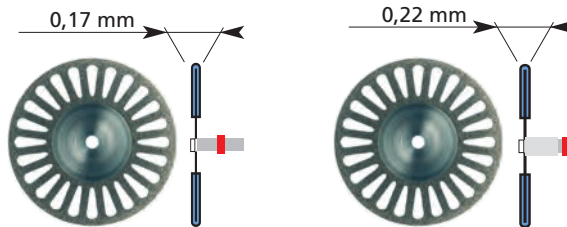

fein, roter Ring / fine, red ring

SEPAFLEX®
3' - 5000 Upm/rpm

402	402	402
220	220	220
1	1	20

182221

132221

1322218

Körnung / grit size
ISO 514
ISO-Nr.
806 104 ...
Figur-Nr. / Shape #
ø 1/10 mm
VE / packaging unit

Order-Nr.

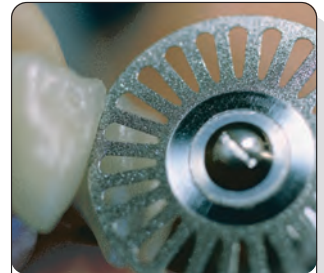

- Keramik
Ceramics
- Komposite
Composites
- montiert und zentriert
mounted and centered
- 20 unmontiert plus 2 Mandrelle
20 unmounted plus 2 mandrels
- auch unmontiert erhältlich
also available unmounted in bulk

doppelseitig
double sided

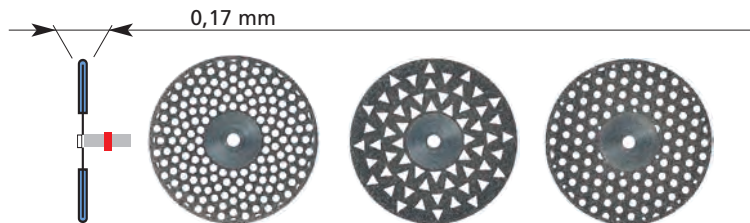

fein, roter Ring / fine, red ring

POLYFLEX **TRI-FLEX** **CIRCO-FLEX**
3' - 5000 Upm/rpm

350	350	350	350
220	220	220	220
1	20	1	1

182231

1822318

182241

182251

Körnung / grit size
ISO 514
ISO-Nr.
806 104 ...
Figur-Nr. / Shape #
ø 1/10 mm
VE / packaging unit

Order-Nr.



- Keramik
Ceramics
- Komposite
Composites
- montiert und zentriert
mounted and centered
- 20 unmontiert plus 2 Mandrelle
20 unmounted plus 2 mandrels
- auch unmontiert erhältlich
also available unmounted in bulk

Flexible Diamantscheiben / Flexible diamond discs

doppelseitig
double sided

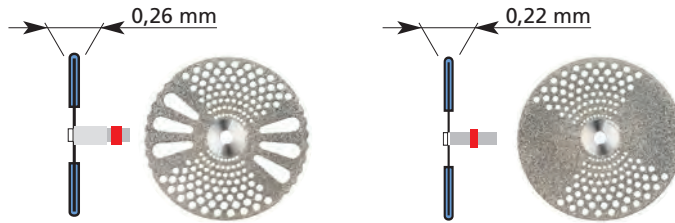

fein, roter Ring / fine, red ring

TECHNO I TECHNO II
3' - 5000 Upm/rpm

Körnung / grit size
ISO 514
ISO-Nr.
806 104 ...
Figur-Nr. / Shape #
ø 1/10 mm
VE / packaging unit

350	350
220	220
1	1

185221

186221

Order-Nr.



doppelseitig
double sided

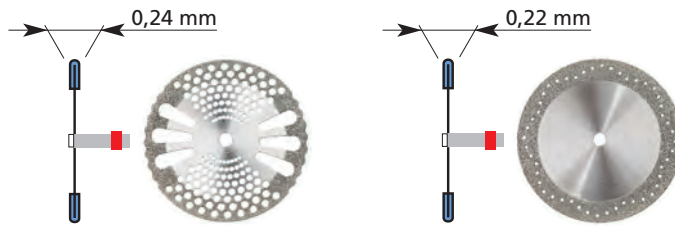

fein, roter Ring / fine, red ring

TECHNO III TECHNO IV
3' - 5000 Upm/rpm

Körnung / grit size
ISO 514
ISO-Nr.
806 104 ...
Figur-Nr. / Shape #
ø 1/10 mm
VE / packaging unit

350	350
220	220
1	1

187221

188221

Order-Nr.



doppelseitig
double sided

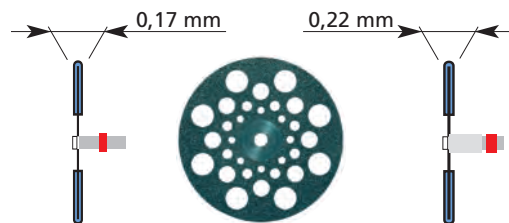

fein, roter Ring / fine, red ring

TRANSOFLEX
3' - 5000 Upm/rpm

Körnung / grit size
ISO 514
ISO-Nr.
806 104 ...
Figur-Nr. / Shape #
ø 1/10 mm
VE / packaging unit

350	350
220	220
1	1

772221

772225

Order-Nr.



Anwendung/Application



- Keramik
Ceramics
- Komposite
Composites
- montiert und zentriert
mounted and centered
- auch unmontiert erhältlich
also available unmounted in bulk



- Keramik
Ceramics
- Komposite
Composites
- montiert und zentriert
mounted and centered
- auch unmontiert erhältlich
also available unmounted in bulk

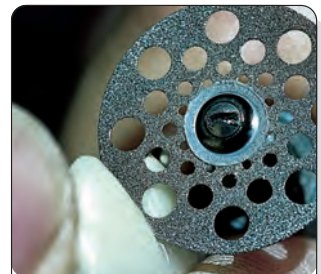

- Zum Separieren / For separating
- Keramik / Ceramics
- Gips / Plaster
- Kunststoffe / Acrylics
- extraharte Verblendkunststoffe
Tough acrylic veneers
- montiert und zentriert
mounted and centered
- auch unmontiert erhältlich
also available unmounted in bulk

Flexible Diamantscheiben / Flexible diamond discs

einseitig
single sided

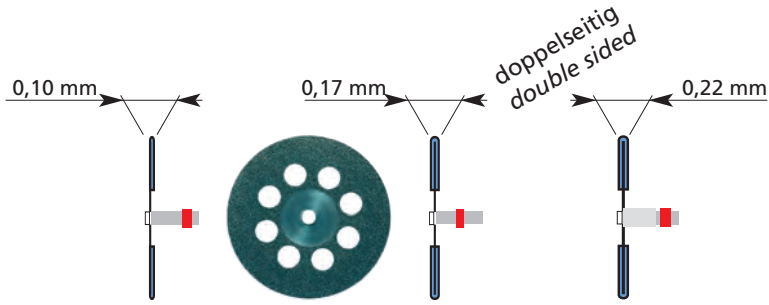

fein, roter Ring / fine, red ring

Körnung / grit size
ISO 514
ISO-Nr.
806 104 ...
Figur-Nr. / Shape #
ø 1/10 mm
VE / packaging unit

PERFOCUT 3' - 5000 Upm/rpm		
351	350	350
210	210	210
1	1	1

272114

272121

272125

Order-Nr.

doppelseitig
double sided

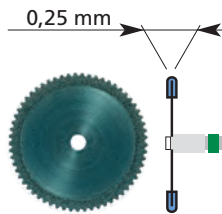

grob, grüner Ring / coarse, green ring

Körnung / grit size
ISO 534
ISO-Nr.
806 104 ...
Figur-Nr. / Shape #
ø 1/10 mm
VE / packaging unit

RAPIDO-CUT 3' - 5000 Upm/rpm	
324	180
1	1

131822

Order-Nr.

doppelseitig
double sided

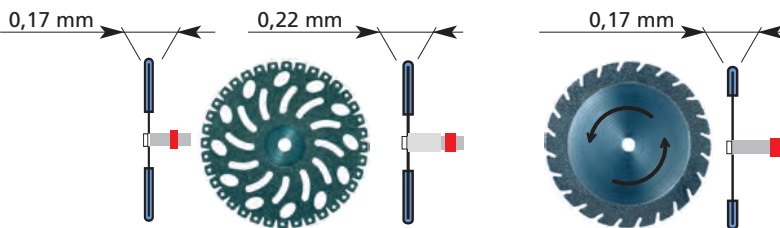

fein, roter Ring / fine, red ring

Körnung / grit size
ISO 514
ISO-Nr.
806 104 ...
Figur-Nr. / Shape #
ø 1/10 mm
VE / packaging unit

SENSOFLEX		CUTFLEX	
3' - 5000 Upm/rpm			
379	379	377	377
220	220	220	220
1	1	1	1

662221

662225

152211

Order-Nr.

Anwendung / Application

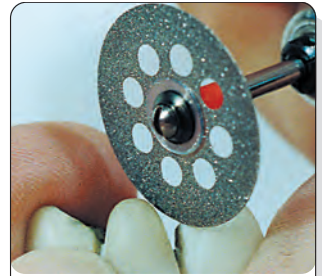

- Zum Separieren / For separating
- Keramik / Ceramics
- Gips / Plaster
- Kunststoffe / Acrylics
- extraharte Verblendkunststoffe
Tough acrylic veneers
- montiert und zentriert
mounted and centered
- auch unmontiert erhältlich
also available unmounted in bulk

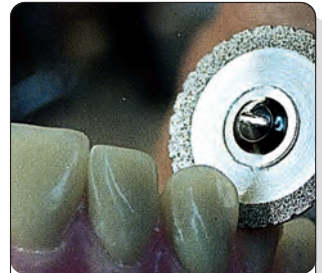

- Zum Separieren von Kunststoffen
in der Totalprothetik,
Tiefziehetechnik und Gips
For separating acrylics at full
prosthetics, deep-drawing
technique and plaster
- montiert und zentriert
mounted and centered
- auch unmontiert erhältlich
also available unmounted in bulk



- Zum Separieren / For separating
- Keramik / Ceramics
- extraharte Verblendkunststoffe
Tough acrylic veneers
- montiert und zentriert
mounted and centered
- auch unmontiert erhältlich
also available unmounted in bulk

Flexible Diamantscheiben / Flexible diamond discs

doppelseitig
double sided

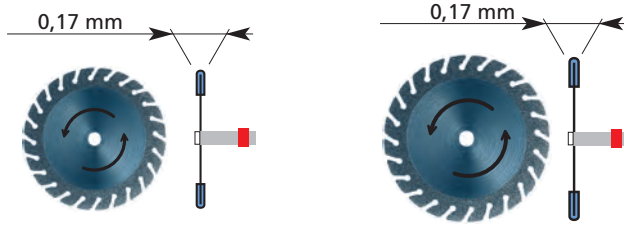

fein, roter Ring / fine, red ring

Anwendung/Application

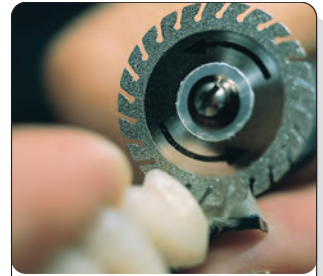

- Nur zum Konturieren / Only for contouring
- Keramik / Ceramics
- extraharte Verblendkunststoffe Tough acrylic veneers
- montiert und zentriert mounted and centered
- auch unmontiert erhältlich also available unmounted in bulk

Körnung / grit size
ISO 514
ISO-Nr.
806 104 ...
Figur-Nr. / Shape #
ø 1/10 mm
VE / packaging unit

LASERFLEX	
5' - 10000 Upm/rpm	
377	377
190	220
1	1

Order-Nr.

151921

152221

doppelseitig
double sided

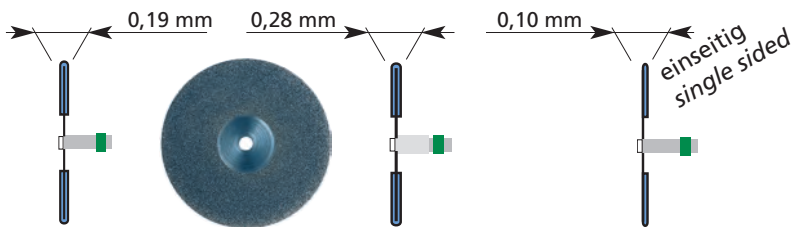

grob, grüner Ring / coarse, green ring



- Zum Separieren und Konturieren For separating and contouring
- Keramik / Ceramics
- Kunststoffe / Acrylics
- Gips / Plaster
- montiert und zentriert mounted and centered
- 3/set (1 St. montiert, 2 St. lose) 3/set (1 pc mounted, 2 pcs unmounted)
- 20 unmontiert plus 2 Mandrelle 20 unmounted plus 2 mandrels
- auch unmontiert erhältlich also available unmounted in bulk

Körnung / grit size
ISO 534
ISO-Nr.
806 104 ...
Figur-Nr. / Shape #
ø 1/10 mm
VE / packaging unit

TOTO-FLEX				
5' - 10000 Upm/rpm				
358	358	358	358	359
220	220	220	220	220
1	3/set	20	1	1

Order-Nr.

112231

1122319

1122318

112241

212214

doppelseitig
double sided

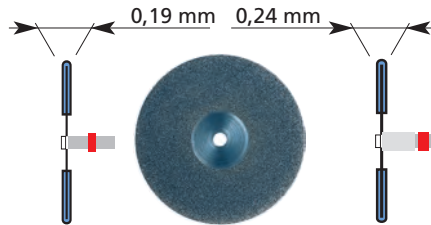

fein, roter Ring / fine, red ring



- Zum Separieren und Konturieren For separating and contouring
- Keramik Ceramics
- Kunststoffe Acrylics
- Gips Plaster
- montiert und zentriert mounted and centered
- auch unmontiert erhältlich also available unmounted in bulk

Körnung / grit size
ISO 514
ISO-Nr.
806 104 ...
Figur-Nr. / Shape #
ø 1/10 mm
VE / packaging unit

TOTO-FLEX	
5' - 10000 Upm/rpm	
358	358
220	220
1	1

Order-Nr.

112233

112251

Flexible Diamantscheiben / Flexible diamond discs

doppelseitig
double sided

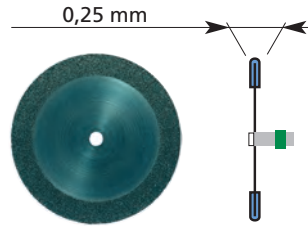

grob, grüner Ring / coarse, green ring

Körnung / grit size
ISO 534
ISO-Nr.
806 104 ...
Figur-Nr. / Shape #
ø 1/10 mm
VE / packaging unit

TORO-FLEX
5' - 10000 Upm/rpm
345
220
1

Anwendung/Application

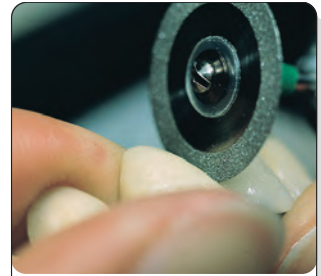

- Zum Separieren und seitlichen Beschleifen
For separating and contouring
- Keramik
Ceramics
- montiert und zentriert
mounted and centered
- auch unmontiert erhältlich
also available unmounted in bulk

Order-Nr.

112242

einseitig
single sided

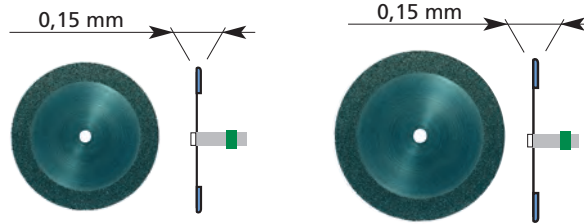

grob, grüner Ring / coarse, green ring

Körnung / grit size
ISO 534
ISO-Nr.
806 104 ...
Figur-Nr. / Shape #
ø 1/10 mm
VE / packaging unit

FLEXIFLEX®
5' - 10000 Upm/rpm

356	356	356
190	220	220
1	1	20

111914

112214

1122148



- Zum Separieren und seitlichem Beschleifen
For separating and contouring
- Keramik
Ceramics
- montiert und zentriert
mounted and centered
- 20 unmontiert plus 2 Mandrelle
20 unmounted plus 2 mandrels
- auch unmontiert erhältlich
also available unmounted in bulk

Order-Nr.

doppelseitig
double sided

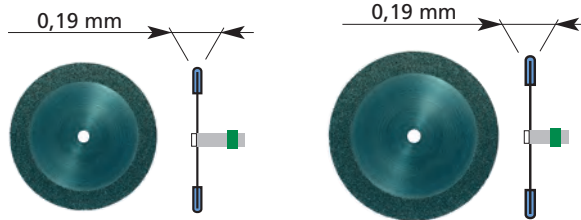

grob, grüner Ring / coarse, green ring

Körnung / grit size
ISO 534
ISO-Nr.
806 104 ...
Figur-Nr. / Shape #
ø 1/10 mm
VE / packaging unit

FLEXIFLEX®
5' - 10000 Upm/rpm

355	355	355	355	355	355
190	190	190	220	220	220
1	3/set	20	1	3/set	20

111921

1119219

1119218

112221

1122219

1122218



- Zum Separieren und seitlichem Beschleifen
For separating and contouring
- Keramik / Ceramics
- montiert und zentriert
mounted and centered
- 3/set (1 St. montiert, 2 St. lose)
3/set (1 pc mounted, 2 pcs unmounted)
- 20 unmontiert plus 2 Mandrelle
20 unmounted plus 2 mandrels
- auch unmontiert erhältlich
also available unmounted in bulk

Order-Nr.

Flexible Diamantscheiben / Flexible diamond discs

! starr, nicht flexibel
rigid, not flexible

Körnung / grit size
ISO 534
ISO-Nr.
806 104 ...
Figur-Nr. / Shape #
ø 1/10 mm
VE / packaging unit



grob, grüner Ring / coarse, green ring

CONO-DISC
5' - 15000 Upm/rpm

Figur-Nr. / Shape #	386	386
ø 1/10 mm	190	220
VE / packaging unit	1	1

161911

162211

Order-Nr.

einseitig
single sided

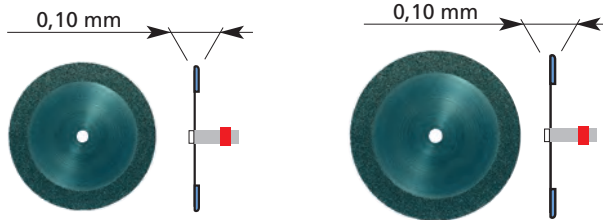

fein, roter Ring / fine, red ring

Körnung / grit size
ISO 514
ISO-Nr.
806 104 ...
Figur-Nr. / Shape #
ø 1/10 mm
VE / packaging unit



SUPER-FLEXIFLEX®
5' - 10000 Upm/rpm

Figur-Nr. / Shape #	356	356
ø 1/10 mm	190	220
VE / packaging unit	1	1

121914

122214

Order-Nr.

doppelseitig
double sided

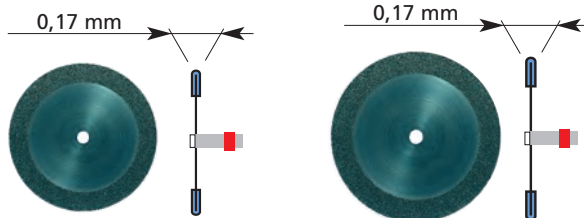

fein, roter Ring / fine, red ring

Körnung / grit size
ISO 514
ISO-Nr.
806 104 ...
Figur-Nr. / Shape #
ø 1/10 mm
VE / packaging unit



SUPER-FLEXIFLEX®
5' - 10000 Upm/rpm

Figur-Nr. / Shape #	355	355	355	355	355
ø 1/10 mm	190	190	220	220	220
VE / packaging unit	1	3/set	1	3/set	20

121921

1219219

12221

122219

122218

Order-Nr.

Anwendung/Application



- Ausarbeiten und Konturieren von Keramik und Komposit
Grinding and contouring of ceramics and composites



- Zum Separieren und Konturieren
For separating and contouring
- Keramik / Ceramics
- montiert und zentriert
mounted and centered
- auch unmontiert erhältlich
also available unmounted in bulk

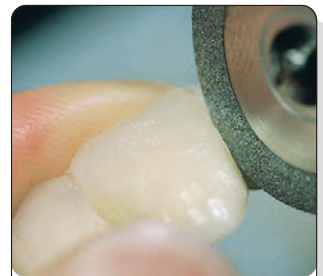

- Zum Separieren und Konturieren
For separating and contouring
- Keramik / Ceramics
- montiert und zentriert
mounted and centered
- 3/set (1 St. montiert, 2 St. lose)
3/set (1 pc mounted, 2 pcs unmounted)
- 20 unmontiert plus 2 Mandrelle
20 unmounted plus 2 mandrels
- auch unmontiert erhältlich
also available unmounted in bulk

Flexible Diamantscheiben / Flexible diamond discs

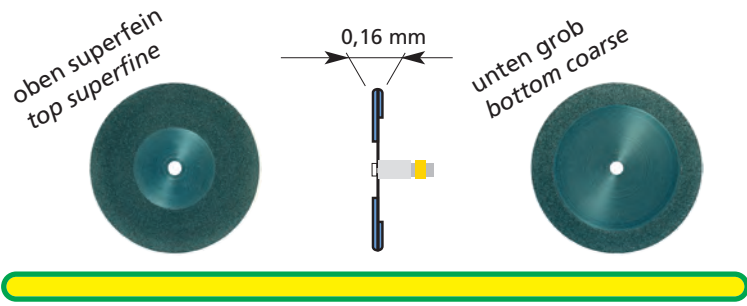

Körnung / grit size
ISO 504 - 534
ISO-Nr.
806 104 ...
 Figur-Nr. / Shape #
 ø 1/10 mm
 VE / packaging unit

DOUBLE ACTION
5' - 10000 Upm/rpm
 355
 220
 1

152231

Order-Nr.

Anwendung/Application



- Zum Separieren und Konturieren
For separating and contouring
- Keramik
Ceramics
- Verblendkunststoffe
Tough acrylic veneers
- montiert und zentriert
mounted and centered
- auch unmontiert erhältlich
also available unmounted in bulk

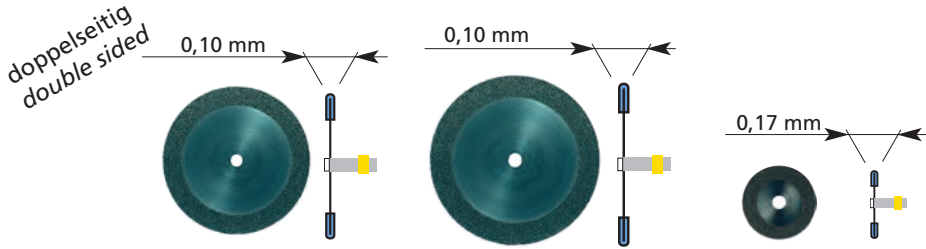

Körnung / grit size
ISO 504
ISO-Nr.
806 104 ...
 Figur-Nr. / Shape #
 ø 1/10 mm
 VE / packaging unit

superfein, gelber Ring / superfine, yellow ring

TOP-FLEX	TOP-FLEX	MINI-FLEX
355	355	355
190	220	090
1	1	1

141921

142221

140921

Order-Nr.

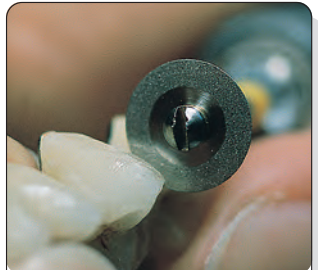

- Zum Separieren und Konturieren
For separating and contouring
- Keramik
Ceramics
- montiert und zentriert
mounted and centered
- auch unmontiert erhältlich
also available unmounted in bulk

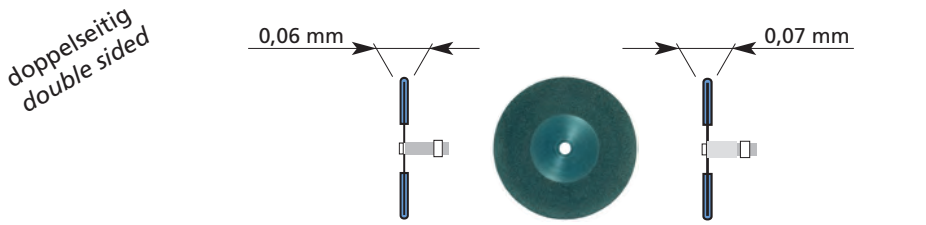

Körnung / grit size
ISO 494
ISO-Nr.
806 104 ...
 Figur-Nr. / Shape #
 ø 1/10 mm
 VE / packaging unit

ultrafein, weißer Ring / ultrafine, white ring

HYDROFLEX	HYDROFLEX
355	355
190	190
1	1

131961

131971

Order-Nr.



- Nur zum Finieren
Only for finishing
- Keramik
Ceramics
- montiert und zentriert
mounted and centered
- auch unmontiert erhältlich
also available unmounted in bulk

Trennscheiben / Separating discs

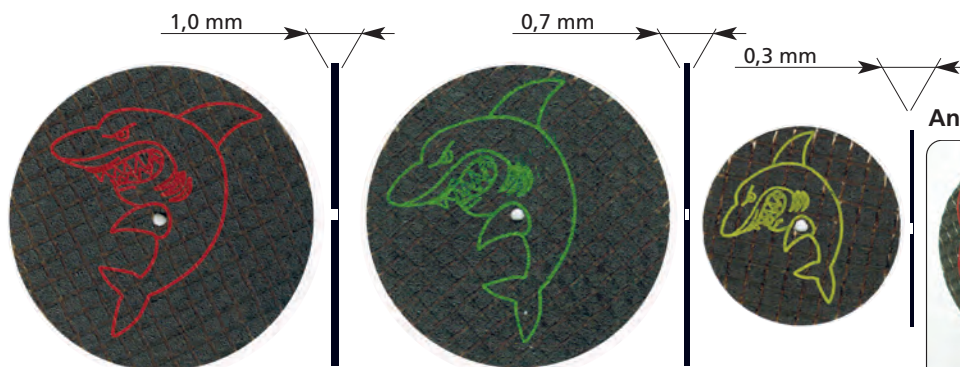

Körnung / grit size
ISO 534 / 514
ISO-Nr.
613 900 ...
Figur-Nr. / Shape #
ø 1/10 mm
VE / packaging unit

SHARK DISCS		
5' - 30000 Upm/rpm	5' - 30000 Upm/rpm	5' - 50000 Upm/rpm
371	371	371
400	400	260
20	20	20
1334018	1334078	1332638

Order-Nr.

Anwendung/Application



- Verstärkte Trennscheiben für sämtliche NE-Metalle mit extrem hoher Standzeit

Reinforced cutting discs for non-precious metals with exceptional long lifetime

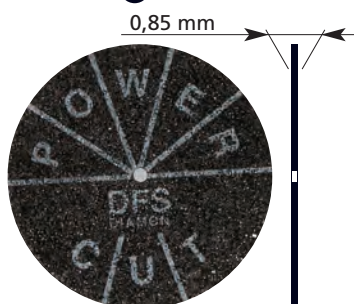

Körnung / grit size
ISO 544
ISO-Nr.
613 900 ...
Figur-Nr. / Shape #
ø 1/10 mm
VE / packaging unit

POWER CUT	
5' - 20000 Upm/rpm	
371	
350	
20	
133525	

Order-Nr.



- Trennscheiben mit hoher Standzeit für sämtliche NE-Metalle

Separating discs, long lasting for all non-precious alloys

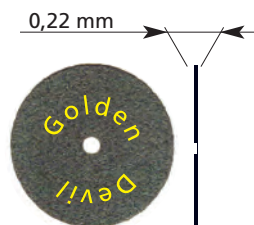

Körnung / grit size
ISO 514
ISO-Nr.
613 900 ...
Figur-Nr. / Shape #
ø 1/10 mm
VE / packaging unit

GOLDEN-DEVIL	
5' - 10000 Upm/rpm	
371	
220	
50	
133622	

Order-Nr.



- Extra dünne Trennscheibe für Edelmetall und andere Metalle

Extra thin separating disc for precious metals and other metals

Gipstrennscheiben / Plaster discs

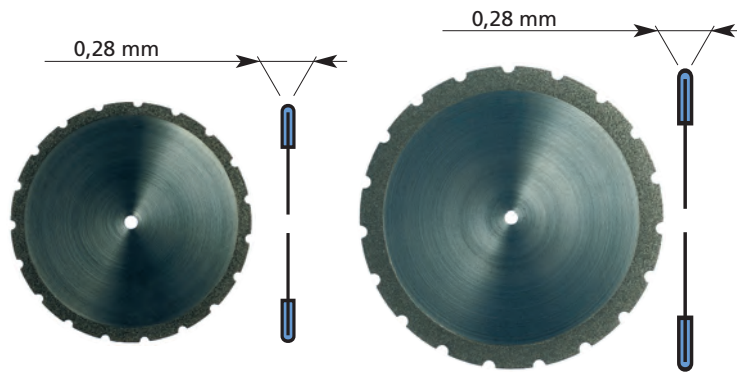

Anwendung/Application



- Gips
Plaster
- Kunstharze
Synthetic resins

Körnung / grit size
ISO 514
ISO-Nr.
806 104 ...
Figur-Nr. / Shape #
ø 1/10 mm
VE / packaging unit

fein, roter Ring / fine, red ring

MINI	PLASTER DISC 5' - 10000 Upm/rpm	MAXI
368		368
320		400
1		1

153222

154022

Order-Nr.



- Gips
Plaster
- Kunstharze
Synthetic resins

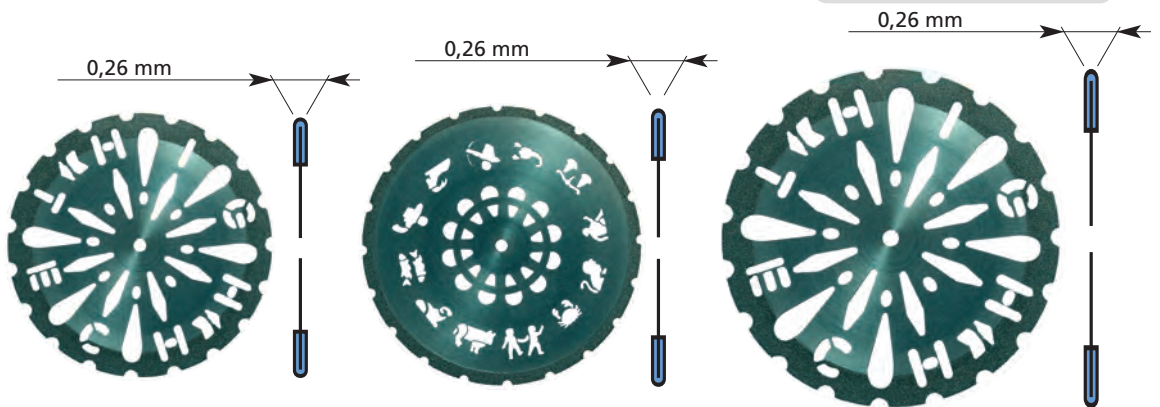

Körnung / grit size
ISO 514
ISO-Nr.
806 104 ...
Figur-Nr. / Shape #
ø 1/10 mm
VE / packaging unit

fein, roter Ring / fine, red ring

HIGH-TECH	PLASTRO 5' - 10000 Upm/rpm	HIGH-TECH
379	379	379
350	370	450
1	1	1

153522

153722

154522

Order-Nr.



Gipstrennscheiben / Plaster discs

Galvanische Diamantierung
Electroplated diamonds

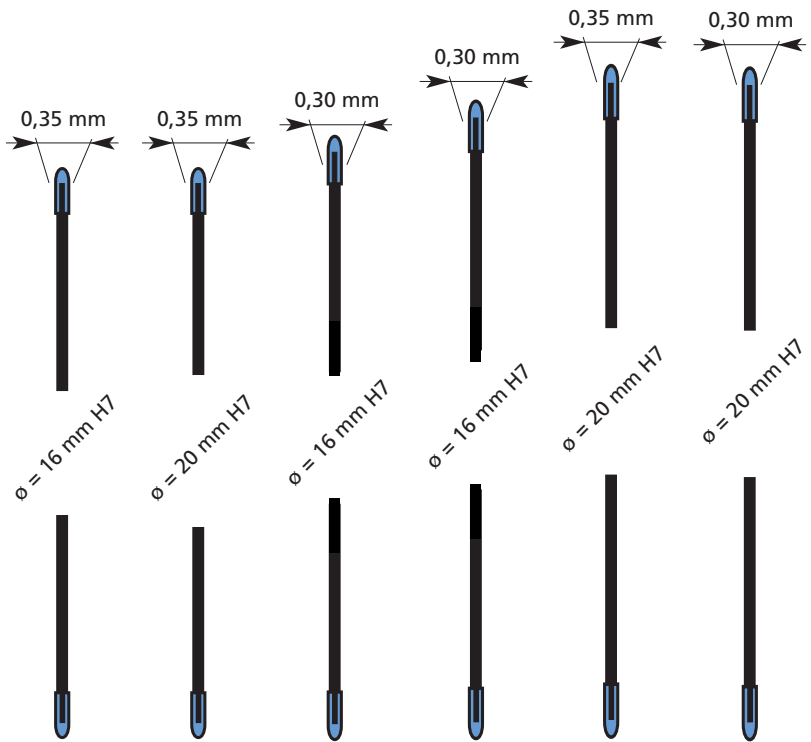

Körnung / grit size
ISO 514
ISO-Nr.
806 000 ...
Figur-Nr. / Shape #
ø 1/10 mm
VE / packaging unit

fein / fine

GIPSTRENNSCHEIBEN / PLASTER CUT DISCS 3' - 5000 Upm/rpm

368	368	368	368	368	368
750	750	800	850	900	900
1	1	1	1	1	1
1575162	1575202	1680162	1685162	1590201	1590202

Order-Nr.

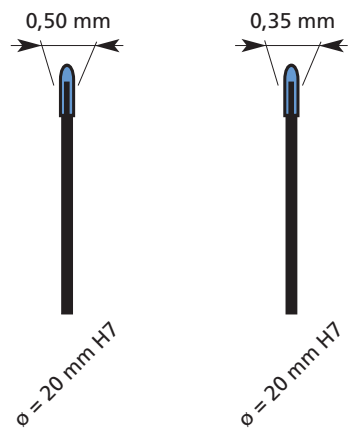

fein / fine

GIPSTRENNSCHEIBEN / PLASTER CUT DISCS 3' - 5000 Upm/rpm

333	333
850	850
1	1
1585232	1585242

Körnung / grit size
ISO 514
ISO-Nr.
806 000 ...
Figur-Nr. / Shape #
ø 1/10 mm
VE / packaging unit

Order-Nr.

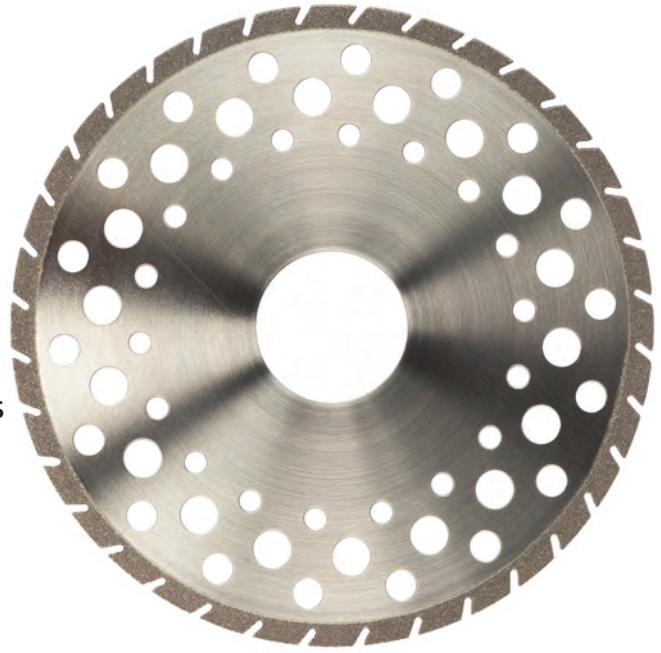

Spezialinstrumente / Special instruments

Diamantiert!
Diamond coated!



Körnung / grit size
ISO 504
ISO-Nr.
806 104 ...
Figur-Nr./Shape #
ø 1/10 mm
VE / packaging unit

superfein, gelber Ring / superfine, yellow ring

STAHLDRAHTBÜRSTE / WIRE BRUSH WHEEL

1' - 3000 Upm/rpm

543
210
1

Anwendung/Application



- Für genarbte Modellgussoberflächen
For stippled partial surfaces
- Achtung: Niedrige Drehzahlen!
Attention: low speed!

Order-Nr.

60014

Diamantiert!
Diamond coated!



Körnung / grit size
ISO 504
ISO-Nr.
806 104 ...
Figur-Nr./Shape #
ø 1/10 mm
VE / packaging unit

superfein, gelber Ring / superfine, yellow ring

STAHLDRAHTPINSEL / WIRE BRUSH

1' - 3000 Upm/rpm

542
060
3

542
060
4/set



- Zum Finieren der Modellgussoberflächen
For finishing surfaces of partials
- Zum Reinigen von Kroninnenflächen
For cleaning of crown interiors
- 4/set (3 Pinsel, 1 Mandrell)
4/set (3 brushes, 1 mandrel)
- Achtung: Niedrige Drehzahl!
Attention: Low speed!

Order-Nr.

60037

60039



MANDRELLE / MANDRELS

**REDUZIERSTÜCKE HST-FG
REDUCERS HP-FG**

**REDUZIERST. 3 -> 2,35 mm
REDUCER 3 -> 2,35 mm**

ISO-Nr.
330 104 ... 391
Figur-Nr./Shape #
ø 1/10 mm
VE / packaging unit

603	603	603	609	610
030	050	070	023	055
12	12	12	1	1

602	619
023	023
3	3

619
030
1

Order-Nr.

509037

509057

509077

81000

810005

505009

505208

50522

Quick-Fix® Mandrell: das revolutionäre Schnellspannsystem

Quick-Fix®: the revolutionary new mandrel system



ISO 612

Quick-Fix® Mandrell gelb / Quick-Fix® mandrel yellow

VE / packaging unit

1

Order-Nr.

810001

doppelseitig
double sided

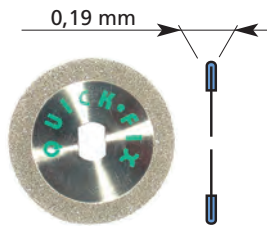

doppelseitig
double sided

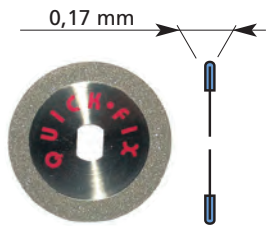

Körnung / grit size
ISO 534
ISO-Nr.
806 900 ...
Figur-Nr. / Shape #
ø 1/10 mm
VE / packaging unit

grob / coarse

FLEXIFLEX®
5' - 10000 Upm/rpm
355 355
220 220
3 5

Körnung / grit size
ISO 514
ISO-Nr.
806 900 ...
Figur-Nr. / Shape #
ø 1/10 mm
VE / packaging unit

fein / fine

SUPER-FLEXIFLEX®
5' - 10000 Upm/rpm
355 355
220 220
3 5

Order-Nr.

1122143F

1122145F

Order-Nr.

1222143F

1222145F

doppelseitig
double sided

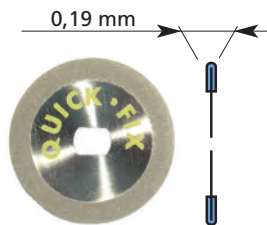

Körnung / grit size
ISO 504
ISO-Nr.
806 900 ...
Figur-Nr. / Shape #
ø 1/10 mm
VE / packaging unit

superfein / superfine

TOPFLEX
5' - 10000 Upm/rpm
355 355
220 220
3 5

Order-Nr.

1422213F

1422215F



Quick-Fix® Mandrell: das revolutionäre Schnellspannsystem

Quick-Fix®: the revolutionary new mandrel system

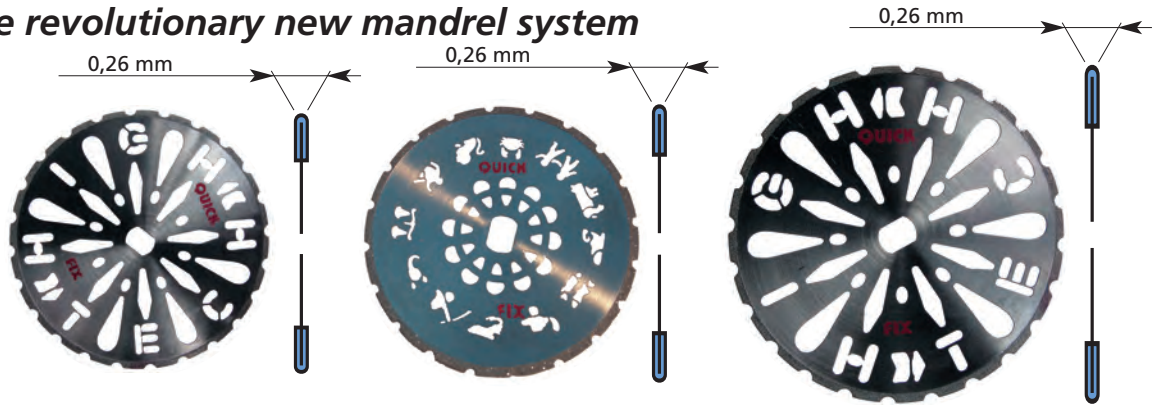

Körnung / grit size
ISO 514
ISO-Nr.
806 900 ...
Figur-Nr. / Shape #
ø 1/10 mm
VE / packaging unit

fein / fine

HIGH-TECH	PLASTRO 5' - 10000 Upm/rpm	HIGH-TECH
379	379	379
350	370	450
1	1	1

1535222F

1537222F

1545222F

Order-Nr.

doppelseitig
double sided

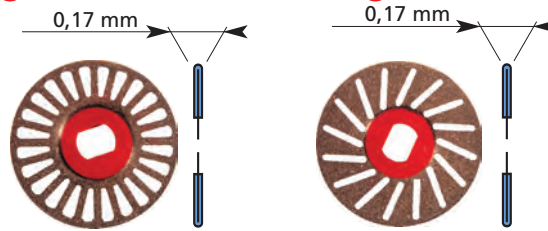

Körnung / grit size
ISO 514
ISO-Nr.
806 900 ...
Figur-Nr. / Shape #
ø 1/10 mm
VE / packaging unit

fein / fine

SEPAFLEX® 3' - 5000 Upm/rpm		PLEXOFLEX	
402	402	389	389
220	220	220	220
3	5	3	5

1822213F

1822215F

1922213F

1922215F

Order-Nr.

Quick-Fix® Set
Quick-Fix® Kit

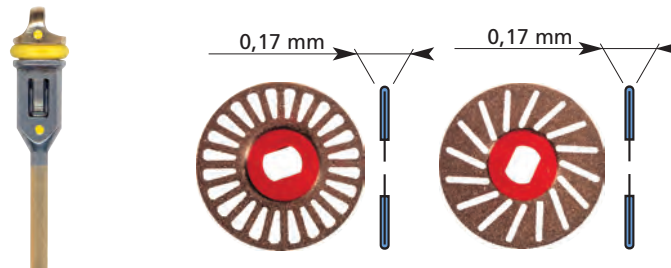

DIAMANTSCHLEIBEN SET / DIAMOND DISC KIT
3' - 5000 Upm/rpm

Order-Nr.

202202F

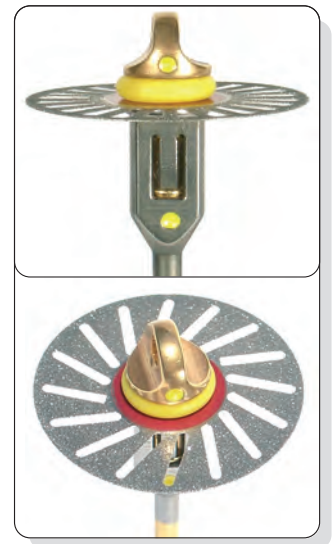

Quick-Fix® Mandrell: das revolutionäre Schnellspannsystem

Quick-Fix®: the revolutionary new mandrel system



ISO 605

Quick-Fix® Mandrell schwarz / Quick-Fix® mandrel black

VE/packaging unit

1

Order-Nr.

810002-1

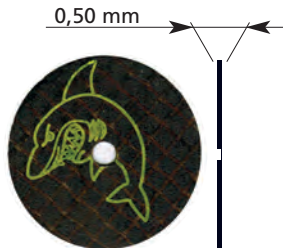
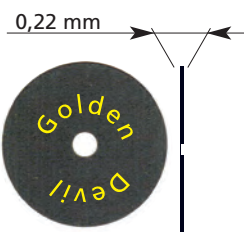

Körnung / grit size
ISO 514
ISO-Nr.
613 900 ...
Figur-Nr. / Shape #
ø 1/10 mm
VE / packaging unit



	GOLDEN-DEVIL	SHARK DISC
	5' - 10000 Upm/rpm	
	371	371
	220	260
	50	50

Order-Nr.

133622F

132522F

Quick-Fix® Set
Quick-Fix® Kit

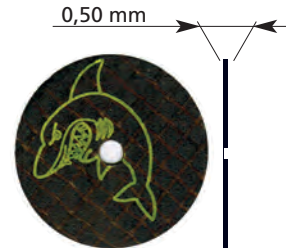
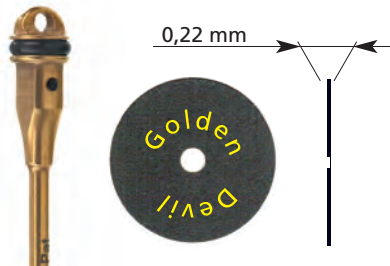

GOLDEN-DEVIL SET / GOLDEN-DEVIL KIT
5' - 10000 Upm/rpm

SHARK DISC SET / SHARK DISC KIT
5' - 10000 Upm/rpm

1 Mandrell + 50 Scheiben / 1 mandrel + 50 discs

1 Mandrell + 50 Scheiben / 1 mandrel + 50 discs

Order-Nr.

202205F

202206F

Smart Fox: die neue Generation des Schnellspanmandrells

Smart Fox: the new fast fixing mandrel system



Ein Mandrell für Diamantscheiben und Trennscheiben.

One mandrel fits both diamond discs and separating discs.

ISO 605

SMART FOX Mandrell / SMART FOX mandrel

rechtsrotierend
right-hand rotating

VE / packaging unit 1

Order-Nr. 8100005F

doppelseitig
double sided

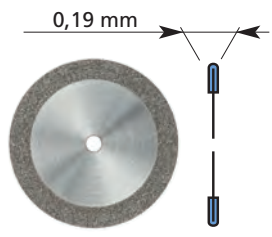

grob / coarse

Körnung / grit size
ISO 534
ISO-Nr. 806 900 ...
Figur-Nr. / Shape # 355
ø 1/10 mm 220
VE / packaging unit 5

FLEXIFLEX®
5' - 10000 Upm/rpm

Order-Nr.

doppelseitig
double sided

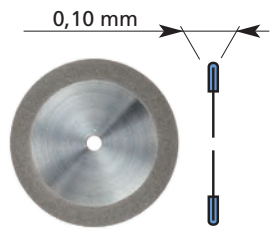

superfein / superfine

Körnung / grit size
ISO 504
ISO-Nr. 806 900 ...
Figur-Nr. / Shape # 355
ø 1/10 mm 220
VE / packaging unit 5

TOPFLEX
5' - 10000 Upm/rpm

Order-Nr.

14222155F



linksrotierend
left-hand rotating

VE / packaging unit 1

Order-Nr. 8200005F

doppelseitig
double sided

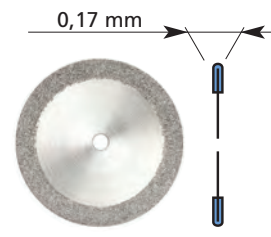

fein / fine

Körnung / grain size
ISO 514
ISO-Nr. 806 900 ...
Figur-Nr. / Shape # 355
ø 1/10 mm 220
VE / packaging unit 5

SUPER-FLEXIFLEX®
5' - 10000 Upm/rpm

Order-Nr.

12221455F



Smart Fox: die neue Generation des Schnellspanmandrells

Smart Fox: the new fast fixing mandrel system

doppelseitig
double sided

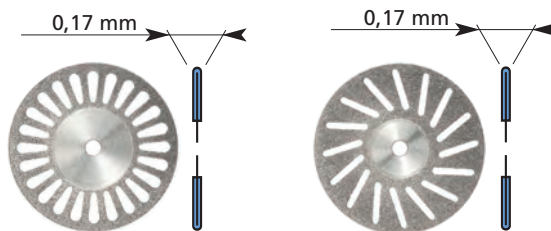

Körnung / grit size
ISO 514
ISO-Nr.
806 900 ...
Figur-Nr. / Shape #
ø 1/10 mm
VE / packaging unit

fein / fine

	SEPAFLEX®	PLEXOFLEX
	3' - 5000 Upm/rpm	
	402	389
	220	220
	5	5
	18222155F	19222155F

Order-Nr.

doppelseitig
double sided

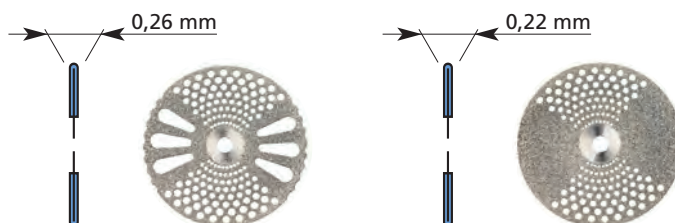

Körnung / grit size
ISO 514
ISO-Nr.
806 900 ...
Figur-Nr. / Shape #
ø 1/10 mm
VE / packaging unit

fein, roter Ring / fine, red ring

	TECHNO I	TECHNO II
	3' - 5000 Upm/rpm	
	350	350
	220	220
	5	5
	18522155F	18622155F

Order-Nr.

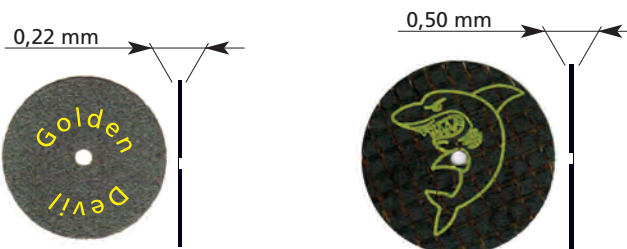

Körnung / grit size
ISO 514
ISO-Nr.
613 900 ...
Figur-Nr. / Shape #
ø 1/10 mm
VE / packaging unit

GOLDEN-DEVIL SHARK DISC

	GOLDEN-DEVIL	SHARK DISC
	5' - 10000 Upm/rpm	
	371	371
	220	260
	50	50
	1336225F	1325225F

Order-Nr.

Ihre Vorteile / Benefits and advantages:

- Adaptive Fähigkeit; die vorher gestaltete Oberflächenstruktur bleibt vollkommen erhalten
Outstanding ability to follow any surfaces and to maintain proper contouring
- Hochbeanspruchbare Faser
Highly flexible and resistant fibres
- Für nahezu sämtliche Dental-Werkstoffe geeignet
Ideal for almost all dental materials

Tipps/Suggestions for use:

Die Anwendung von UPOFIX® erfordert für effektiven Einsatz durchzugskräftige Micromotoren, gerade im unteren Drehzahlbereich.

UPOFIX® polishers are most efficient if used in conjunction with a high torque Micro Motor at low speed.

Niedrige Drehzahl: <i>Low speed:</i>	circa 2000-3000 Upm <i>approx. 2000-3000 rpm</i>	hoher Anpreßdruck <i>firm pressure</i>	leichte Abrasion <i>light abrasion</i>
--	---	--	--

Erhöhte Drehzahl: <i>Higher speed:</i>	circa 3000-5000 Upm <i>approx. 3000-5000 rpm</i>	geringer Anpreßdruck <i>light pressure</i>	Glanz-Politur <i>high shine</i>
--	---	--	---

ACHTUNG!

Die angewandte Drehzahl bei UPOFIX® sollte nur **2000-5000 Upm** betragen. Eine intermittierende Arbeitsweise mit mäßig starkem Druck und gleichzeitig kreisenden, diagonal zu führenden Bewegungen ist für gute Ergebnisse zu empfehlen!

CAUTION!

Do not exceed 5000 rpm. For best results we recommend intermittent, moderate pressure, moving in diagonal and circular motion.

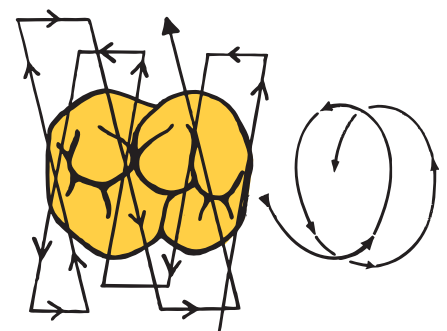
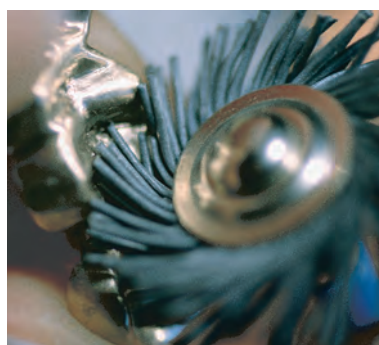
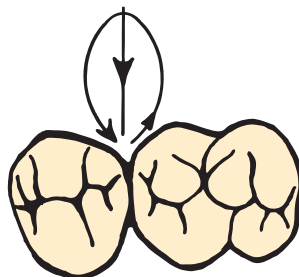

UPOFIX® Universal Polierer / UPOFIX® universal polishers

Anwendung/Application

ISO-Nr.
653 104 543 542
ø 1/10 mm
VE/packaging unit
Order-Nr.

extragrob, schwarzer Ring / extracoarse, black ring

UPOFIX® 0
2' - 5000 Upm/rpm
210 210
3 5
802207 802209
● ø 21 mm ●



- Für sämtliche Metalle
For all metals

ISO-Nr.
653 104 543 532
ø 1/10 mm
VE/packaging unit
Order-Nr.

extragrob, schwarzer Ring / extracoarse, black ring

UPOFIX® I
2' - 5000 Upm/rpm
210 210
3 5
802217 802219
● ø 21 mm ●



- Speziell für Kauflächen und Interdentalräume
Especially for occlusal and interproximal areas
- Für sämtliche Metalle als Vorpolierer
Prepolisher for all metals

ISO-Nr.
653 104 543 512
ø 1/10 mm
VE/packaging unit
Order-Nr.

mittel, blauer Ring / medium, blue ring

UPOFIX® II
2' - 5000 Upm/rpm
210 210
3 5
802227 802229
● ø 21 mm ●



- Speziell für Kauflächen und Interdentalräume
Especially for occlusal and interproximal areas
- Für sämtliche Metalle als Glanzpolierer
Final polisher for all metals

ISO-Nr.
653 104 543 522
ø 1/10 mm
VE/packaging unit
Order-Nr.

grob, grüner Ring / coarse, green ring

UPOFIX® III
2' - 5000 Upm/rpm
210 210
3 5
802237 802239
● ø 21 mm ●



- Für Keramik als Vorpolierer
Prepolisher for ceramics

ISO-Nr.
653 104 543 502
ø 1/10 mm
VE/packaging unit
Order-Nr.

fein, roter Ring / fine, red ring

UPOFIX® IV
2' - 5000 Upm/rpm
210 210
3 5
802247 802249
● ø 21 mm ●



- Für Keramik als Glanzpolierer
Final polisher for ceramics
- Für Komposite und Kunststoff als Vorpolierer
Prepolisher for composites and acrylics

ISO-Nr.
653 104 543 492
ø 1/10 mm
VE/packaging unit
Order-Nr.

superfein, gelber Ring / superfine, yellow ring

UPOFIX® V
2' - 5000 Upm/rpm
210 210
3 5
802257 802259
● ø 21 mm ●



- Für Komposite und Kunststoff als Glanzpolierer
Final polisher for composites and acrylics

UPOFIX® Universal Polierer / UPOFIX® universal polishers



Anwendung/Application

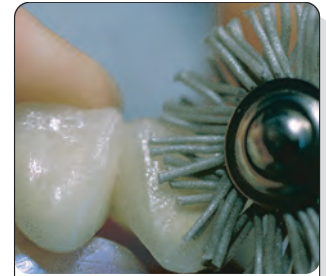

- Set -> je 1 Stück 0, I, II, III, IV, V
- Set -> one each 0, I, II, III, IV, V

ISO-Nr.
653 104 ...
ø 1/10 mm
VE/packaging unit

UPOFIX® SET
2' - 5000 Upm/rpm
210
set

802279

Order-Nr.



Polierinstrumente / Polishing Instruments

Durchgehend diamantiert!
Impregnated with diamonds!



superfein, gelber Ring / superfine, yellow ring

Körnung / grit size
ISO 502
ISO-Nr.
653 104 ...
Figur-Nr. / Shape #
ø 1/10 mm
VE / packaging unit

UNIFIX
2' - 3000 Upm/rpm

541	542	543
070	045	150
2	2	2

801919

801949

801929

Order-Nr.



- Keramik
Ceramics
- Komposite
Composites
- Achtung! Niedrige Drehzahl und intermittierender Druck
Caution! Low speed and intermittent pressure

Ziegenhaarbürste
Goat hair brush



Körnung / grit size
ISO 502
ISO-Nr.
090 104...
Figur-Nr. / Shape #
ø 1/10 mm
VE / packaging unit

GOAT FIX
5' - 10000 Upm/rpm

543	543
150	190
6	6

803010

803011

Order-Nr.



- Edelmetall
Precious alloys
- Komposite
Composites
- Alle Kunststoffe
all acrylics

Polierpaste erforderlich.
Polishing paste needed.

Polierinstrumente / Polishing instruments

DIADURIT®- imprägniert! 1-3µ
DIADURIT®- impregnated! 1-3µ

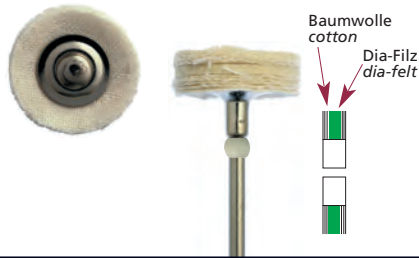

Körnung / grit size
ISO 491
ISO-Nr.
080 104 ...
Figur-Nr. / Shape #
ø 1/10 mm
VE / packaging unit



SUPERSHINY
2' - 3000 Upm/rpm

372
170
3

803028



Order-Nr.

Anwendung/Application

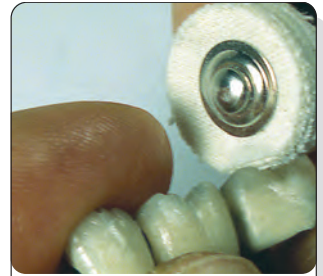

- Metalle
Metals
- Keramik
Ceramics
- Komposite
Composites
- 1 St. montiert, 2 St. lose
1 pc mounted, 2 pcs unmounted

Naturhaar mit integrierter Polierpaste
Natural fibres impregnated with polishing paste



Körnung / grit size
ISO 491
ISO-Nr.
110 104 ...
Figur-Nr. / Shape #
ø 1/10 mm
VE / packaging unit



HYPOFIX-GAMMA
1' - 3000 Upm/rpm

372
220
3

803059



Order-Nr.



- Für sämtliche Dental-Legierungen
For all dental alloys
- Für okklusale Flächen
For occlusal surfaces
- 1 St. montiert, 2 St. lose
1 pc mounted, 2 pcs unmounted

Mit integrierter Polierpaste
Impregnated with polishing paste

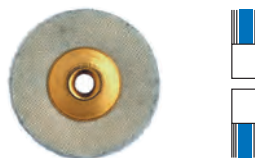

Körnung / grit size
ISO 491
ISO-Nr.
080 104 ...
Figur-Nr. / Shape #
ø 1/10 mm
VE / packaging unit



HYPOFIX-DELTA
1' - 3000 Upm/rpm

372
200
3

803019



Order-Nr.



- Für sämtliche Dental-Legierungen
For all dental alloys
- Für labiale, vestibuläre Flächen
For labial, vestibular areas
- 1 St. montiert, 2 St. lose
1 pc mounted, 2 pcs unmounted

Polierinstrumente / Polishing instruments

DIADURIT®- imprägniert! 5µ
DIADURIT®- impregnated! 5µ

Ohne DIADURIT®
Without DIADURIT®

ultrafein / ultrafine

		DIAFIX®		1' - 3000 Upm/rpm	
Körnung / grit size		372	372	372	274
ISO 491		150	150	120	050
ISO-Nr.		10	12	10	3
070 104/900 ...					12
Figur-Nr./Shape #		800418	80041-12	801229	800439
ø 1/10 mm		○	○	○	○
VE / packaging unit					○
Order-Nr.					

Anwendung/Application



- Keramik
Ceramics
- Komposite
Composites
- Einschließlich 1 Mandrell
1 mandrel included

Polierbürsten / Polishing brush wheels

Für die hygienische Kunststoffpolitur
ohne Schlammbad!
Long-lasting brush wheels
for mud-free polishing!

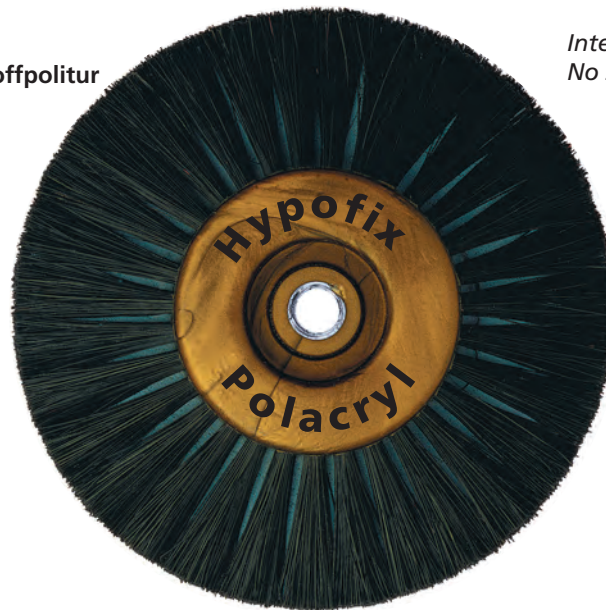

HYPOFIX-POLACRYL
1' - 3000 Upm /rpm

Körnung / grit size		543
ISO 491		800
ISO-Nr.		2
100 000 ...		
Figur-Nr./Shape #		803038
ø 1/10 mm		○
VE / packaging unit		
Order-Nr.		

Ihre Vorteile / Your benefits:

- Mit integrierter Polierpaste.
Kein Spritzen und kein Schmieren!

Integrated polishing paste!
No sputtering and no smearing!

Anwendung/Application

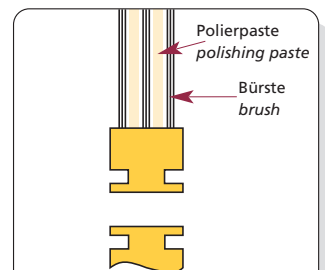

- Für schlammfreies und hygienisches Trockenpolieren von Kunststoffprothesen
For mud free and hygienic dry polishing of acrylic dentures

Polierbürsten / Polishing brush wheels



Körnung / grit size
 ISO 491
**ISO-Nr.
 100 000 ...**
 Figur-Nr. / Shape #
 ø 1/10 mm
 VE / packaging unit



HYPOFIX-ALPHA
 1' - 3000 Upm/rpm

543
 800
 2

803039



Order-Nr.

Anwendung/Application

- Für sämtliche Dental-Legierungen
For all dental alloys
- Polieren mit enormer Standzeit
Polishing with extremely long life time



Körnung / grit size
 ISO 491
**ISO-Nr.
 100 000 ...**
 Figur-Nr. / Shape #
 ø 1/10 mm
 VE / packaging unit



HYPOFIX-BETA
 1' - 3000 Upm/rpm

543
 550
 2

803029



Order-Nr.

- Für sämtliche Dental-Legierungen
For all dental alloys
- Polieren mit enormer Standzeit
Polishing with extremely long life time

Spezial Polierer / Special polishers

Körnung / grit size
ISO 542
ISO-Nr.
653 104 ...
 Figur-Nr. / Shape #
 ø 1/10 mm
 VE / packaging unit



extragrob, schwarzer Ring / extracoarse, black ring

DURO-POL
5' - 10000 Upm/rpm

292	292	292	292
070	070	100	100
6	50	6	50

Order-Nr. 800239 800237 800249 800247

Anwendung/Application



- Für sämtliche Metalle / All metals
- Für sämtliche Kunststoffe All acrylics
- Für weichbleibende Kunststoffe For soft lining materials

Körnung / grit size
ISO 523
ISO-Nr.
658 900 ...
 Figur-Nr. / Shape #
 ø 1/10 mm
 VE / packaging unit



grob, grüner Ring / coarse, green ring

PALAPOL
5' - 10000 Upm/rpm

275	275	275	275	275	275
120	120	100	100	080	080
6	50	6	50	6	50

Order-Nr. 800279 800277 800289 800287 800269 800267



- Für sämtliche Metalle / All metals
- Silikon-Polierer zum Finieren (Sanden) von Heiß- und Kaltpolymerisaten / For finishing of heat curing and self-curing acrylics
- Für weichbleibende Kunststoffe For soft lining materials
- 6 St. lose, 1 Mandrell
 6 pcs unmounted, 1 mandrel

Körnung / grit size
ISO 513
ISO-Nr.
658 900 ...
 Figur-Nr. / Shape #
 ø 1/10 mm
 VE / packaging unit



fein, roter Ring / fine, red ring

PALAPOL
5' - 10000 Upm/rpm

275	275	275	275	275	275
120	120	100	100	080	080
6	50	6	50	6	50

Order-Nr. 800379 800377 800389 800387 800369 800367



- Für sämtliche Metalle / All metals
- Silikon-Polierer zum Finieren (Sanden) von Heiß- und Kaltpolymerisaten / For finishing of heat curing and self-curing acrylics
- Für weichbleibende Kunststoffe For soft lining materials
- 6 St. lose, 1 Mandrell
 6 pcs unmounted, 1 mandrel

Spezial Polierer / Special polishers

Körnung / grit size
 ISO 502
 ISO-Nr.
 612 104 ...
 Figur-Nr. / Shape #
 ø 1/10 mm
 VE / packaging unit



superfein, gelber Ring / superfine, yellow ring

SABELKING
 5' - 10000 Upm/rpm

Figur-Nr. / Shape #	292
ø 1/10 mm	100
VE / packaging unit	3

800259

●

Anwendung/Application



- Ideal für Übergänge von Kunststoffsaßeln / Metall
Ideal for polishing combined acrylic / metal surfaces
- Valplast
Valplast

Order-Nr.

Körnung / grit size
 ISO 504
 ISO-Nr.
 612 900 ...
 Figur-Nr. / Shape #
 ø 1/10 mm
 VE / packaging unit



superfein, gelber Ring / superfine, yellow ring

UNI-POL
 10' - 20000 Upm/rpm

Figur-Nr. / Shape #	372	303	114
ø 1/10 mm	220	220	060
VE / packaging unit	50	50	50

600509

600529

600519

● ● ●



- NE-Legierungen
Non-precious alloys
- Edelmetall-Legierungen
Precious alloys
- 50 St. lose, 1 Mandrell
50 pcs bulk, 1 mandrel

Order-Nr.

Körnung / grit size
 ISO 512
 ISO-Nr.
 653 900 ...
 Figur-Nr. / Shape #
 ø 1/10 mm
 VE / packaging unit



fein, roter Ring / fine, red ring

MULTIPOL PREPOLISH
 5' - 10000 Upm/rpm

Figur-Nr. / Shape #	373	303	114
ø 1/10 mm	220	220	060
VE / packaging unit	50	50	50

600539

600549

600559

● ● ●



- NE-Legierungen
Non-precious alloys
- 50 St. lose, 1 Mandrell
50 pcs bulk, 1 mandrel

Order-Nr.

Spezial Polierer / Special polishers

Körnung / grit size
ISO 502
ISO-Nr.
653 900 ...
Figur-Nr. / Shape #
ø 1/10 mm
VE / packaging unit

superfein, gelber Ring / superfine, yellow ring

MULTIPOL SHINE 5' - 10000 Upm/rpm		
373	303	114
220	220	060
50	50	50

600639
600649
600659

Order-Nr.

Anwendung/Application



- NE-Legierungen
Non-precious alloys
- 50 St. lose, 1 Mandrell
50 pcs bulk, 1 mandrel

Körnung / grit size
ISO 523
ISO-Nr.
658 900 ...
Figur-Nr. / Shape #
ø 1/10 mm
VE / packaging unit

ultrafein, weißer Ring / ultrafine, white ring

SILCO-POL 5' - 10000 Upm/rpm					
372	372	303	303	114	114
220	220	200	200	060	060
6	50	6	50	6	50

812059
812057
812049
812047
812069
812067

Order-Nr.



- Weicher Silikonpolierer
Soft silicone polisher
- Edelmetall-Legierungen
Precious alloys
- NE-Legierungen
Non-precious alloys
- Komposite / Composites
- Keramik / Ceramics
- 1 St. montiert, 5 St. lose
1 pc mounted, 5 pcs unmounted
- 50 St. lose, 1 Mandrell
50 pcs bulk, 1 mandrel

Körnung / grit size
ISO 502
ISO-Nr.
803 104 ...
Figur-Nr. / Shape #
ø 1/10 mm
VE / packaging unit

superfein, gelber Ring / superfine, yellow ring

TOP-GLAZE		
3' - 18000 Upm/rpm	3' - 12000 Upm/rpm	3' - 10000 Upm/rpm
292	372	303
050	150	150
3	3	3

800299
800129
800309

Order-Nr.

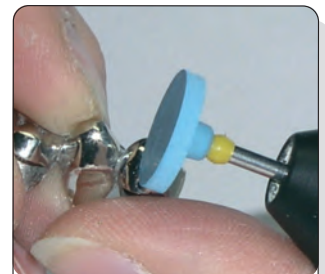

- Voll diamantiert, zur absoluten Hochglanzpolitur
Fully impregnated with diamonds, for absolute mirror finish
- Keramik
Ceramics
- Alle Metalle
All metals

Spezial Polierer / Special polishers

Körnung / grit size
 ISO 502
ISO-Nr.
803 104 ...
 Figur-Nr. / Shape #
 ø 1/10 mm
 VE / packaging unit

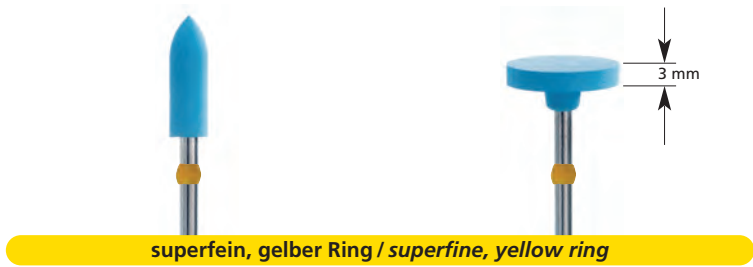

TOP-GLAZE SET

3' - 18000 Upm/rpm	3' - 12000 Upm/rpm
292	372
050	150

Set je 1 St. / 1pc each

Order-Nr.

800122



Anwendung/Application

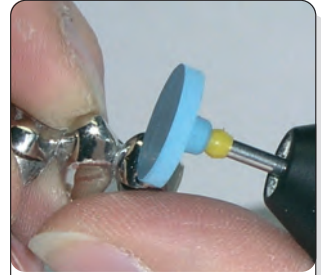

- Voll diamantiert, zur absoluten Hochglanzpolitur
Fully impregnated with diamonds, for mirror finish
- Keramik
Ceramics
- Alle Metalle
All metals

Körnung / grit size
 ISO 532
ISO-Nr.
652 900 ...
 Figur-Nr. / Shape #
 ø 1/10 mm
 VE / packaging unit

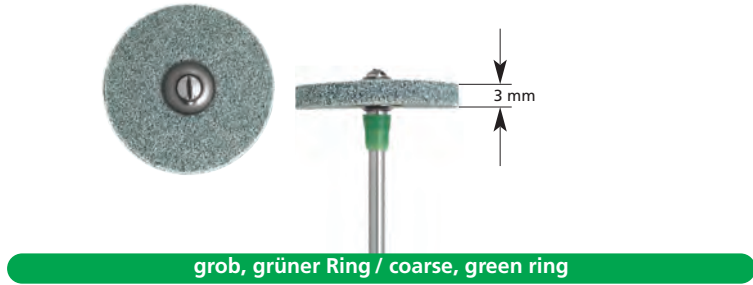

POLO

5' - 10000 Upm/rpm	372	372
	220	220
	12	50

Order-Nr.

812079

812077



- Polierer für sämtliche Metalle, insbesondere Co-Cr
Polisher for all metals especially Co-Cr
- Keramik
Ceramics
- 1 St. montiert, 11 St. lose
1 pc mounted, 11 pcs unmounted
- 50 St. lose, 1 Mandrell
50 pcs bulk, 1 mandrel

Körnung / grit size
 ISO 522
ISO-Nr.
652 900 ...
 Figur-Nr. / Shape #
 ø 1/10 mm
 VE / packaging unit

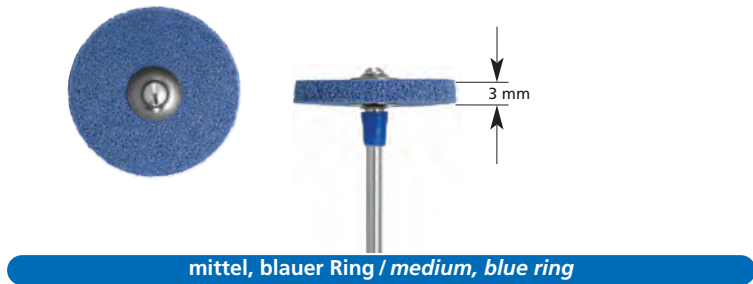

POLLI

5' - 10000 Upm/rpm	372	372
	220	220
	12	50

Order-Nr.

812089

812087



- Polierer für sämtliche Metalle, insbesondere Co-Cr
Polisher for all metals especially Co-Cr
- Keramik
Ceramics
- 1 St. montiert, 11 St. lose
1 pc mounted, 11 pcs unmounted
- 50 St. lose, 1 Mandrell
50 pcs bulk, 1 mandrel

Spezial Polierer / Special polishers

Körnung / grit size
ISO 524
ISO-Nr.
803 104 ...
 Figur-Nr. / Shape #
 ø 1/10 mm
 Polierstufe
 VE / packaging unit

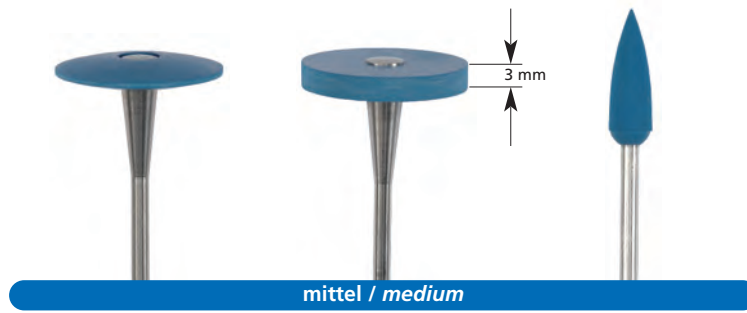

mittel / medium

TITANOPOL
3' - 6000 Upm/rpm

303	372	243
220	220	055
1	1	1
1	1	1
800701	800702	800703

Order-Nr.

Anwendung/Application



- Diamantierte Polierer zur Titanbearbeitung
Diamond-impregnated polishers for titanium
- einzeln montiert
single mounted

Körnung / grit size
ISO 514
ISO-Nr.
803 104 ...
 Figur-Nr. / Shape #
 ø 1/10 mm
 Polierstufe
 VE / packaging unit



fein / fine

TITANOPOL
3' - 6000 Upm/rpm

303	372	243
220	220	055
2	2	2
1	1	1
800704	800705	800706

Order-Nr.



- Diamantierte Polierer zur Titanbearbeitung
Diamond-impregnated polishers for titanium
- einzeln montiert
single mounted

Körnung / grit size
ISO 504
ISO-Nr.
803 104 ...
 Figur-Nr. / Shape #
 ø 1/10 mm
 Polierstufe
 VE / packaging unit

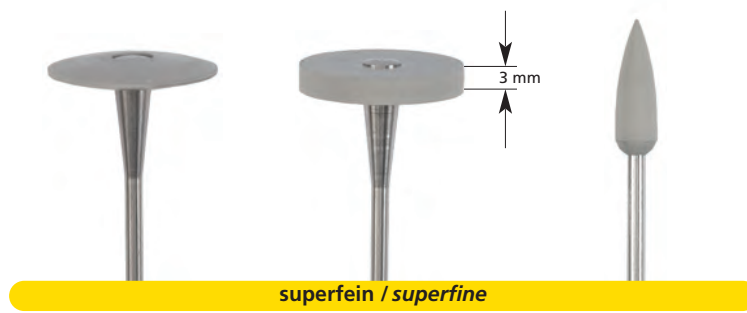

superfein / superfine

TITANOPOL
3' - 6000 Upm/rpm

303	372	243
220	220	055
3	3	3
1	1	1
800707	800708	800709

Order-Nr.



- Diamantierte Polierer zur Titanbearbeitung
Diamond-impregnated polishers for titanium
- einzeln montiert
single mounted

Verzahnung / Cut
 ISO 377
 ISO-Nr.
 310 104 ...
 Figur-Nr. / Shape #
 ø 1/10 mm
 VE / packaging unit

kein Ring / without ring

WACHSFRÄSER / WAXCUTTER
 3' - 5000 Upm/rpm

471	471	471	471
016	023	030	040
1	1	1	1

80090 80060 80070 80080

○ ○ ○ ○

Anwendung / Application

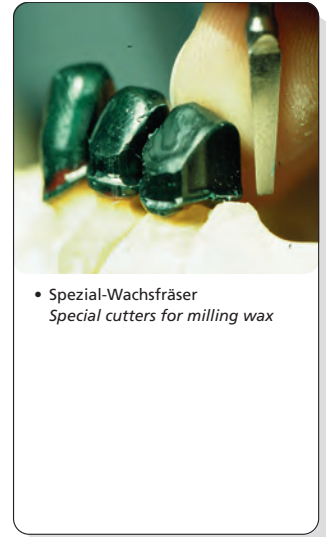

Verzahnung / Cut
 ISO 366
 ISO-Nr.
 500 103 ...
 Figur-Nr. / Shape #
 ø 1/10 mm
 VE / packaging unit

kein Ring / without ring

WACHSFRÄSER / WAXCUTTERS
 3' - 6000 Upm/rpm

137	137	137
010	015	023
1	1	1

115712L 115722L 115732L

○ ○ ○

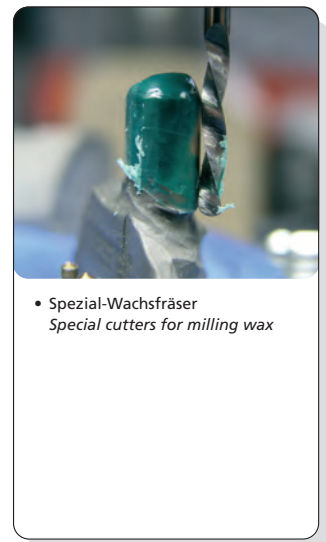

Verzahnung / Crosscut
 ISO 220
 ISO-Nr.
 500 103 ...
 Figur-Nr. / Shape #
 ø 1/10 mm
 VE / packaging unit

grob, kein Ring / coarse, without ring

VORFRÄSER GROB / MILLING BUR COARSE
 6' - 12000 Upm/rpm

137	137	137
010	015	023
1	1	1

115422L 115432L 115442L

● ● ●



Order-Nr.

Verzahnung / Crosscut
 ISO 190
 ISO-Nr.
 500 103 ...
 Figur-Nr. / Shape #
 ø 1/10 mm
 VE / packaging unit



mittel, kein Ring / medium, without ring

VORFRÄSER MITTEL / MILLING BUR MEDIUM
 6' - 12000 Upm/rpm

137	137	137
010	015	023
1	1	1

115602L 115612L 115622L

Order-Nr.

Anwendung/Application

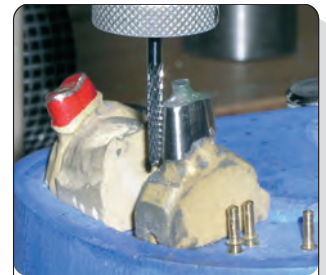

- Diadur
Vorfräser für Frästechnik
- Diadur
milling bur

Verzahnung / Cut
 ISO 135
 ISO-Nr.
 500 103 ...
 Figur-Nr. / Shape #
 ø 1/10 mm
 VE / packaging unit



fein, kein Ring / fine, without ring

FINIERFRÄSER / FINISHING BURS
 6' - 12000 Upm/rpm

137	137	137
010	015	023
1	1	1

115802L 115812L 115822L

Order-Nr.



- Diadur
Finierfräser für Frästechnik
- Diadur
finishing burs for milling
technique

Körnung / grit size
 ISO 522/512/502
 ISO-Nr.
 653/803 103 ...
 Figur-Nr. / Shape #
 ø 1/10 mm
 VE / packaging unit

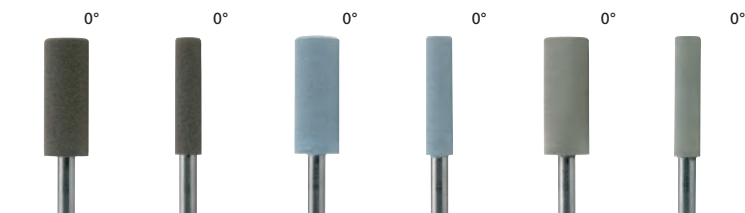

mittel / medium fein / fine superfein / superfine

MILLIPOL 0°
 5' - 10000 Upm/rpm

114	113	114	113	114	113
060	033	060	033	060	033
1	1	1	1	1	1

80061 80071 80062 80072 80063 80073

Order-Nr.

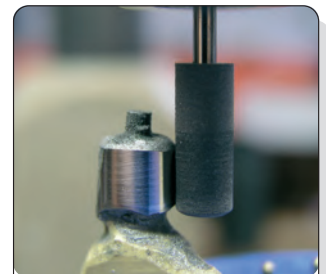

- Vorpolierer (braun),
Polierer (blau, grau)
für Frästechnik
- Prepolisher (brown),
polishers (blue, grey) for milling
technique
- Polierer für gefräste Umläufe und
Stufen
- Polishers for milled bracings and
ledges

Verzahnung / Cut
 ISO 006
 ISO-Nr.
 500 103 ...
 Figur-Nr. / Shape #
 ø 1/10 mm
 VE / packaging unit

0°	0°	0°
kein Ring / without ring		fein / fine
TWISTERS		BOHRFRÄSER / CENTERING BUR
6' - 12000 Upm/rpm		6' - 12000 Upm/rpm
442	423	419
010	015	009
1	1	1
115410	115415	115412
○	○	●

Order-Nr.

Anwendung / Application



- Twister: zum Bohren von Inter-Locks u.a.
Twister: for drilling of inter-locks and similar
- Bohrfräser: zum Zentrieren der Bohrposition
Centering bur: punch for centering of the twister position

Verzahnung / Cut
 ISO 131
 ISO-Nr.
 500 103 ...
 Figur-Nr. / Shape #
 ø 1/10 mm
 VE / packaging unit

	0°		0°
fein, kein Ring / fine, without ring			
STIRNFRÄSER / SHOULDER CUTTING BURS			
6' - 12000 Upm/rpm			
138		138	
015		023	
1		1	
115515		115523	
●		●	

Order-Nr.



- Fräsen von Schultern ohne Beeinträchtigung bereits gefräster Flächen
Milling of shoulders without damage to already milled vertical surfaces

Verzahnung / Cut
 ISO 175
 ISO-Nr.
 500 103 ...
 Figur-Nr. / Shape #
 ø 1/10 mm
 VE / packaging unit

0°	0°	0°	0°
fein, kein Ring / fine, without ring			
RILLENFRÄSER / GROOVE CUTTERS			
6' - 12000 Upm/rpm			
111	111	111	111
010	012	016	020
1	1	1	1
115012	115112	115212	115312
●	●	●	●

Order-Nr.

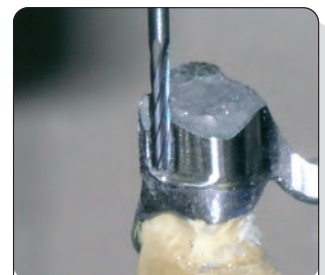

- Zum Fräsen seitlicher Friktionsrillen
For milling of lateral grooves